

GENERAL SERVICE MANUAL



Stinson

Model 108 Series Airplanes

STINSON DIVISION



UNIVAIR AIRCRAFT CORPORATION

Rt. 3 Box 59, Aurora, CO 80011 Ph: (303) 364-7661

TABLE OF CONTENTS—Cont'd

	<i>Page</i>
Aileron and Flap Removal.....	35
Aileron and Flap Installation.....	35
Empennage Structure	35
Rudder Removal	35
Rudder Trim Tab Removal.....	37
Elevator Removal	38
Elevator Trim Tab Removal.....	38
Stabilizer Removal	38
Fin	39
Stabilizer Installation	39
Elevator Installation	39
Elevator Trim Tab Installation.....	40
Rudder Installation	40
Rudder Trim Tab Installation.....	40
 Chapter IV—CONTROL SYSTEMS	
General	41
Cables	41
Control Surfaces Travel	41
Control Systems Maintenance	43
Control Column	43
Elevator Control System	45
Elevator Control System Adjustment	45
Aileron Control System	45
Aileron Control System Adjustment	47
Lateral Trim	47
Flap Control System	47
Flap Control System Adjustment	49
Rudder Control System	51
Rudder Control System Adjustment	51
Rudder Trim Bungee System	51
Rudder Trim Bungee Control Adjustment	51
Rudder Trim Tab Control	53
Rudder Trim Tab Control Adjustment	53
Elevator Trim Tab Control System.....	54

TABLE OF CONTENTS—Cont'd

	<i>Page</i>
 Chapter V—LANDING GEAR, BRAKES, AND WHEELS	
General	55
Main Landing Gear	55
Beam Removal	57
Beam Maintenance	57
Beam Installation	57
Shock Absorber Struts	58
Shock Absorber Removal and Disassembly.....	58
Shock Absorber Strut Maintenance	59
Shock Absorber Strut Installation	59
Main Landing Gear Wheels	59
Main Landing Gear Wheel Removal	61
Tool for Removal of Brake Disc Spring Clips.....	61
Main Landing Gear Wheels Maintenance	61
Main Wheel Bearings Maintenance	63
Main Landing Gear Wheels Installation	63
Tire Removal	64
Tire Maintenance	64
Tire Installation	64
Main Landing Gear Brakes	65
Brake Master Cylinders	67
Wheel Brake Replacements	68
Wheel Brake Periodic Maintenance	69
Filling the Brake System	69
Bleeding the Brakes	69
Draining the Brake System	70
Tail Landing Gear	71
Tail Landing Gear Removal	71
Tail Landing Gear Maintenance	72
 Chapter VI—POWER PLANT	
Propeller	73
Propeller Installation	73
Propeller Tracking	73
Engine Cowl	74
Engine Cowl Removal	74

TABLE OF CONTENTS—Cont'd

	<i>Page</i>
Engine	74
Engine Specification	76
Engine Operation	77
Inadequate Fuel Supply	77
Underpriming	77
Overpriming	77
Incorrect Mixture	77
Ignition Malfunctioning	77
Improper Carburetion	79
Improper Valve Action	80
Engine Operating with Low Oil Pressure	81
Low Power	83
Rough Running	84
High Oil Temperature	85
Valve Rocker Adjustment	85
Engine Removal	86
Engine Installation	87
Engine Controls	87
Engine Cooling System	87
Engine Exhaust System	88
Carburetor Air Heater	88
Carburetor Air Filter	88
Carburetor	89
Carburetor Adjustment	91
Magnetos	92
Magneto Breaker Point Setting	92
Magneto Timing	93
Spark Plugs	94
Ignition System Maintenance	95
Oil System	95
Oil Cooler	95
Oil Pressure Relief Adjusting Valve	96
Oil System Maintenance	96
Draining Oil	97
Fuel System	97
Fuel Tanks	99

TABLE OF CONTENTS—Cont'd

	<i>Page</i>
Fuel Tank Removal	100
Fuel Tank Repair	101
Fuel Tank Installation	101
Fuel Selector Valve	102
Engine Primer	102

Chapter VII—ELECTRICAL SYSTEM

General	103
Battery	103
Battery Removal	108
Battery Maintenance	108
Battery Installation	108
Generator	108
Generator Maintenance	109
Voltage Regulator	109
Circuit Breakers	109
Starter	110
Starter Maintenance	110
Lights	110
List of Electrical Equipment	110

Chapter VIII—HEATING AND VENTILATING SYSTEM

Heater (Model 108)	113
Heater (Models 108-1 and up)	113
Heater Maintenance	113
Heater Muff Removal	114
Heater Muff Installation	115
Ventilation	116

Chapter IX—INSTRUMENTS

Instrument Panel	117
Instrument Panel Removal	117
Instrument Panel Installation	117
Airspeed Indicator Maintenance	118
Compass Compensation	119
Instrument Markings	121

TABLE OF CONTENTS—Cont'd

	<i>Page</i>
Chapter X—RADIO SYSTEM	
Transmitter-Receiver Unit	123
Power Unit	123
Antennae	123
Headphones	127
Operation	127
Maintenance	128
Chapter XI—SERVICE INSPECTION	
Safety Precautions	129
Lubrication	129
Preflight Inspection	129
Daily Inspection	129
Weekly, or 25 Flying Hours Inspection.....	130
One-Hundred Hour Inspection.....	131
Major Overhaul Period.....	135
Special Inspections	135

LIST OF ILLUSTRATIONS

Chapter I—SPECIFICATIONS		
<i>Figure</i>	<i>Title</i>	<i>Page</i>
	The Model 108-3	
1	Three View Drawing of Airplane.....	2
2	Side View Drawing of Model 108-3.....	3
	The Model 108-2	4
Chapter II—GROUND HANDLING AND GENERAL MAINTENANCE		
3	Mooring Airplane	5
4	Rear of Cabin for Cargo.....	6
5	Cargo Tie-Down	7
6	Hoisting Airplane	8
7	Jacking Airplane	9
8	Battery Filling	11
9	Seat Track Stop Bolt.....	12
10	Oil Filler and Dip Stick.....	13
11	Oil Drain	14
12	Access Provisions	16
13	Power Plant Lubrication Points.....	18
14	Cabin Lubrication Points.....	19
15	Landing Gear Lubrication Points.....	20
16	Wing Lubrication Points.....	21
17	Empennage Lubrication Points.....	22
Chapter III—AIRFRAME STRUCTURE		
18	Fabric Repair Methods.....	24
19	Fuselage Structure (Models 108, -1, -2).....	26
20	Fuselage Structure (Model 108-3).....	27
21	Wing Drag Wires.....	32
22	Empennage Assembly (Models 108, -1, -2).....	36
23	Empennage Assembly (Model 108-3).....	37
Chapter IV—CONTROL SYSTEMS		
24	Control Column Assembly.....	43
25	Controls Under Pilot's Floor.....	44

LIST OF ILLUSTRATIONS—Cont'd

<i>Figure</i>	<i>Title</i>	<i>Page</i>
26	Elevator Control System.....	46
27	Aileron Control System.....	48
28	Flap Control System.....	49
29	Rudder Control System.....	50
30	Trim Tab Control Systems.....	52

Chapter V—LANDING GEAR, BRAKES, AND WHEELS

31	Main Landing Gear Assembly.....	56
32	Shock Absorber Assembly.....	58
33	Main Wheel Assembly.....	60
34	Tool for Removing Brake Disc Spring Clips.....	62
35	Brake System (Models 108, -1, -2).....	65
36	Brake System (Model 108-3).....	66
37	Brake Master Cylinder Assembly.....	67
38	Brake Assembly	68
39	Tail Landing Gear Assembly.....	71

Chapter VI—POWER PLANT

40	Propeller and Cowling Installation.....	74
41	Engine Left Side (Model 108).....	78
42	Engine Right Side (Model 108).....	79
43	Engine Left Side (Models 108-1, -2, -3).....	80
44	Engine Right Side (Models 108-1, -2, -3).....	81
45	Engine Front (Model 108).....	82
46	Bleeding Down Hydraulic Valve Lifters.....	86
47	Carburetor	89
48	Ignition Wiring Diagram.....	90
49	Interior of Eiseman Magneto.....	91
50	Engine Timing Marks.....	92
51	Magneto Timing	94
52	Oil Drain	97
53	Fuel System	98
54	Fuel Strainer	99
55	Fuel Tank	100

LIST OF ILLUSTRATIONS—Cont'd

<i>Figure</i>	<i>Title</i>	<i>Page</i>
---------------	--------------	-------------

Chapter VII—ELECTRICAL SYSTEM

56	Electrical System (Models 108, -1, -2).....	104
57	Electrical Wiring Diagram (Models 108, -1, -2).....	105
58	Electrical System (Model 108-3).....	106
59	Electrical Wiring Diagram (Model 108-3).....	107
	The Model 108	112

Chapter III—HEATING AND VENTILATION SYSTEM

60	Cabin Heating and Ventilating System (Model 108).....	114
61	Cabin Heating and Ventilating System (Models 108-1, -2, -3).....	115

Chapter IX—INSTRUMENTS

62	Instrument Panel	118
63	Instrument Lines	120

Chapter X—RADIO SYSTEM

64	Radio System (Model 108).....	124
65	Radio Cording Diagram (Model 108).....	125
66	Radio System (Model 108-1, -2, -3).....	126
67	Radio Cording Diagram (Model 108-1, -2, -3).....	127



CHAPTER I

SPECIFICATIONS

GENERAL

1. The Stinson Model 108 Series airplanes are four-engine, high-wing, cabin monoplanes manufactured by the Stinson Division of Consolidated Vultee Aircraft Corporation. These airplanes are powered with horizontally opposed, six cylinder, air-cooled Franklin engines. They are equipped with wing flaps, slotted wings, brakes, steerable tail wheel, and dual controls.

2. Reference hereafter to the features peculiar to each model of the series is by model designation. The following table identifies the various models.

<i>Year</i>	<i>Model</i>	<i>Power</i>	<i>Gross Weight</i>
1946	108	150	2150
1947	108-1	150	2230
1947	108-2	165	2230
1948	108-3	165	2400

3. The airplane model and serial number is stamped on a nameplate mounted on the cabin side of the firewall, in front of the right seat. The airplane serial number is also stamped on the engine side of the firewall at the upper right hand corner.

4. The engine serial number is stamped on the engine nameplate attached to the left side of the engine crankcase. On early airplanes the engine nameplate is mounted on top of the engine just ahead of the starter.

WEIGHT AND BALANCE

5. The weight empty for each airplane is given on the weight and balance sheets supplied with the airplane.

6. The following table lists the Center of Gravity Limits for each of the models. Values given are for gross weight loading. Inches are from wing leading edge and percent figures are of M.A.C.

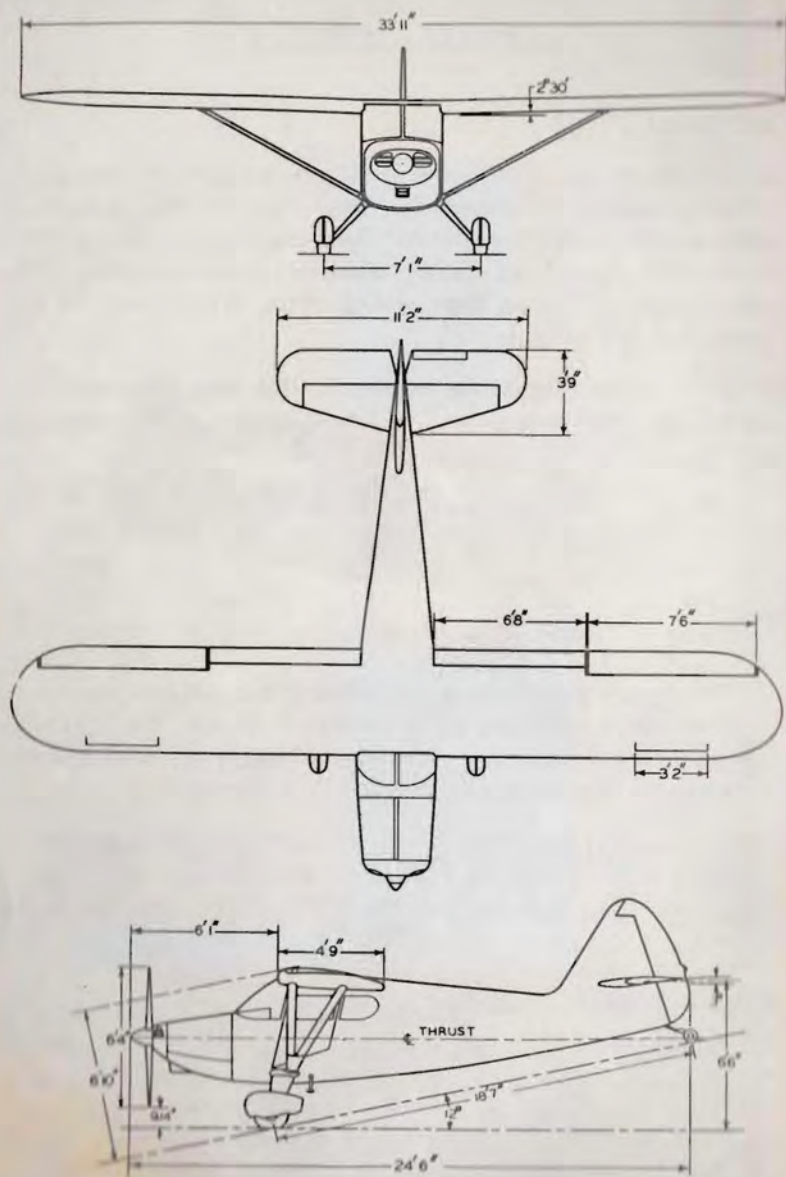

Figure 1—Three View Drawing of Airplane

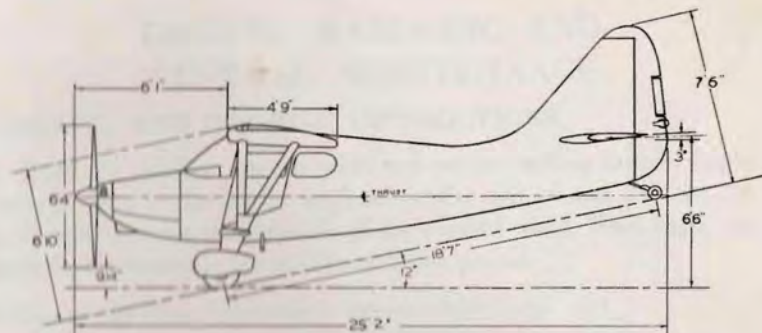

Figure 2—Side View Drawing of Model 108-3

Model	Forward		Aft	
	Inches	Percent	Inches	Percent
108	10.62	18.2	20.03	35.2
108-1	10.62	18.2	21.33	37.5
108-2	10.62	18.2	21.33	37.5
108-3	10.62	18.2	21.89	38.5

AREAS

	Square Feet
Wing (gross)	155.00
Ailerons (each)	9.01
Flaps (each)	6.11
Horizontal Stabilizer	14.66
Elevator (Including tab)	17.24
Elevator Trim Tab	0.94
Fin (Models 108, -1, & -2)	8.55
Fin (Model 108-3)	14.28
Rudder (Models 108, -1, & -2)	6.28
Rudder (Including Trim Tab, Model 108-3)	6.78
Rudder Trim Tab (Model 108-3)	0.49



The Model 108-2

CHAPTER II

GROUND HANDLING AND GENERAL MAINTENANCE

PARKING AND MOORING INSTRUCTIONS

1. Head the airplane into the wind and set the parking brakes. Apply force to both brake pedals until the brakes are set and pull out the push-pull knob on the left side of the control panel. Hold knob out until foot pressure is released from brake pedals.
2. Lower the flaps full-down to prevent buffeting.
3. Aileron and elevator controls may be locked by pulling control wheel back and securing with seat belt. Rudder controls do not normally require locking since rudder is held by tail wheel steering springs.
4. When high winds are anticipated or airplane is to be parked for an extended period, it is recommended that the airplane be moored. Refer to figure 3. Attach mooring ropes to the tail wheel leaf spring at the rear of the fuselage and to each wing. On models 108, -1 & -2, it is necessary to loop ropes around the upper ends of the front lift struts for wing tie-down points. On the model 108-3 a special mooring ring is attached to the front spar near each wing tip. Stake the ropes to the ground leaving sufficient slack to allow for shortening of the ropes due to moisture or rain.

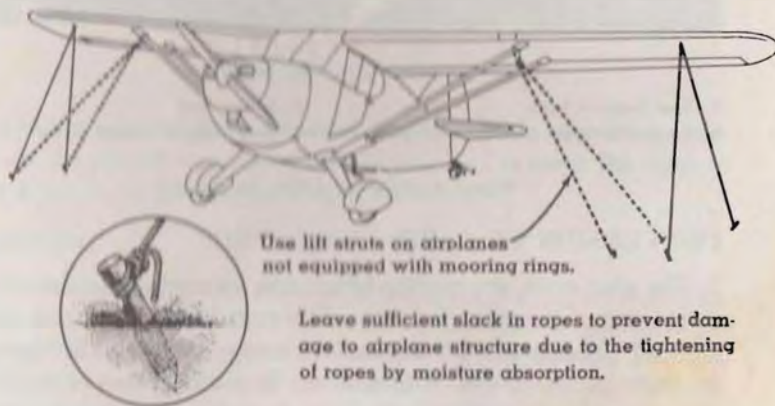
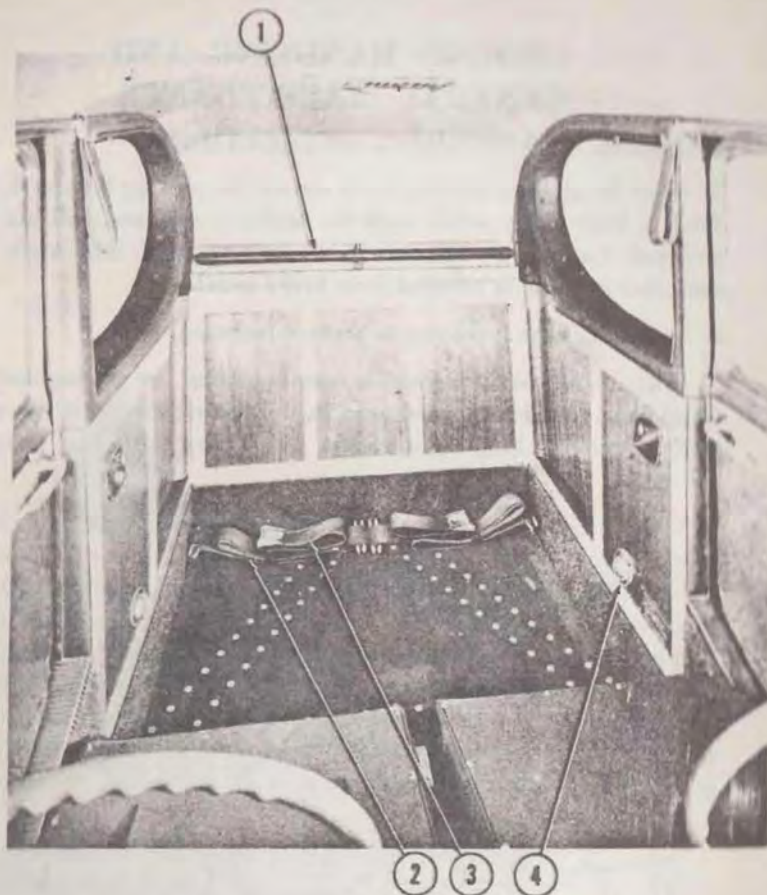

Figure 3—Mooring Airplane



- | | |
|------------------------|-------------------------------|
| 1. Seat Support Tube | 3. Safety Belt |
| 2. Cargo Tie-Down Belt | 4. Seat Support Fitting Cover |

Figure 4—Rear of Cabin for Cargo

CONVERSION OF CABIN FOR CARGO

5. The rear seats are readily removable permitting the use of the entire rear of the cabin for cargo. It is permissible to carry a maximum of 350 pounds of cargo in the Voyager cabin and 600 pounds of cargo in the Station Wagon cabin. To remove rear seats lift off seat cushions, unbuckle straps from forward support tube at the bottom, and from aft support tube at the top. Three straps support

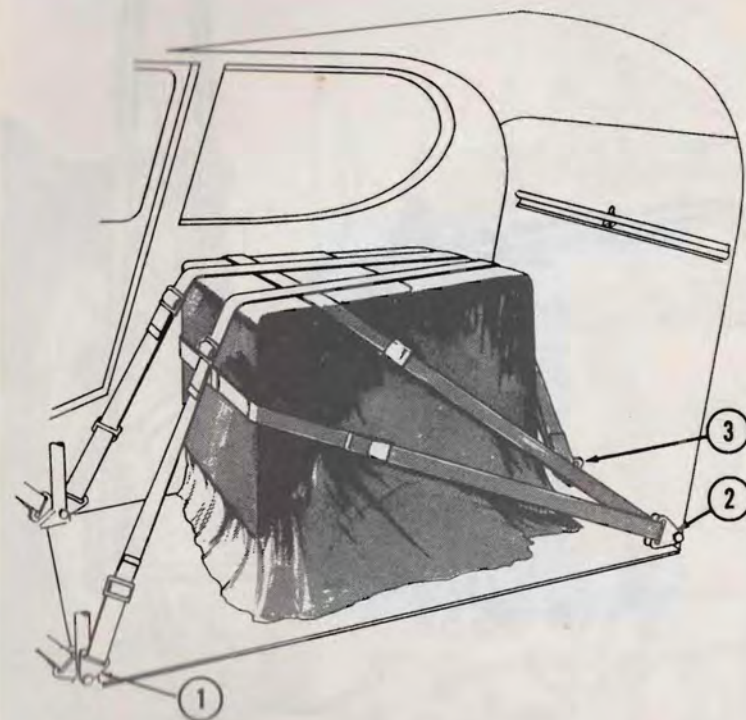

- | | |
|------------------------------|------------------------------|
| 1. Outer Front Seat Belt Lug | 2. Outer Rear Seat Belt Lug |
| | 3. Center Rear Seat Belt Lug |

Figure 5—Cargo Tie-Down

each of the two rear seats. Forward support tube is removed by taking out the pins at each end. Caps are provided to cover the support tube brackets in the Station Wagon airplanes.

HOISTING

6. A hoisting sling can be attached to the upper engine mount fittings at the fire wall. The method of attaching the sling is illustrated in figure 6. Before the sling can be attached the side cowling must be removed. Detach the front of the hinge from the nose cowl, the rear of the hinge from the fuselage. On model 108-3 airplanes the battery must be removed to permit attachment of sling.



Figure 6—Hoisting Airplane

7. It is recommended that ropes be used for hoisting. If it is necessary to use a chain or a cable, use padding to prevent damage to the fittings. A hoist with a capacity of at least 1500 pounds is required to lift the airplane when it is empty. When hoisting at the engine mount fittings, means must be provided to keep the wings of the airplane level.

JACKING

8. The jack points are located at two places underneath the fuselage and at each landing gear leg as illustrated in figure 7. The forward jack point is accessible by detaching the fillets on the landing gear fairing at the fuselage and by removing the metal cover under the fuselage. Place the jack in position on the plate under the frame tube cluster. Pad the jack to prevent damage to the tubes.

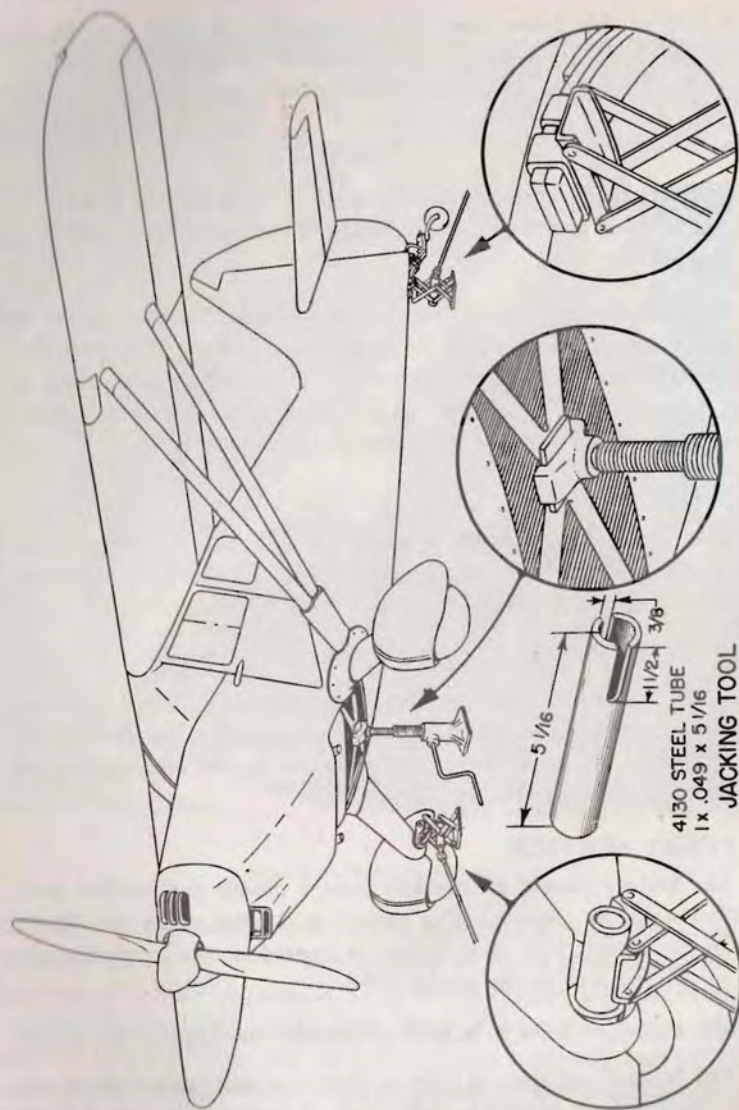

Figure 7—Jacking Airplane

9. A jack at this point must have a capacity of 1500 pounds, an initial height of 18 inches, and a stroke of 14 inches to clear the main wheels from the ground if either or both tires are flat.

CAUTION

When jacking at this point the airplane must be tied down at the wing struts or mooring rings to prevent it from rolling off the jack.

10. As illustrated in figure 7, a jack can be used to raise either of the main landing gear wheels by inserting a jacking tool, part No. 108-5901000, in the axle. A jack used here must have a capacity of 1000 pounds, an initial height of four inches, and a stroke of six inches to clear the wheel from the ground if the tire is flat.

LEVELING

11. The upper edge of the door frame, which is parallel to the thrust line, can be used to level the airplane. Use a spirit level for checking the attitude of the airplane.

TIRE INFLATION

12. For maximum tire service, keep tires inflated to proper pressure. The recommended tire pressure is the airplane weight divided by 100. Example: 22 psi is the correct pressure for an airplane loaded to 2200 pounds gross weight.

BATTERY SERVICE

13. The battery should be checked once a month and refilled with distilled water as required. The battery is located under the pilot's seat in the models 108, -1 & -2, and is located on the forward right side of the fire wall in the model 108-3.

14. Fill Exide batteries to a level of one-half inch above the plates.

15. Fill Willard batteries as follows. Batteries with vented plugs are to be filled to level of visible baffle plate. Batteries with sealed plugs are to be filled to top of plug chamber WHILE SEALING VENT WITH FINGER OR BY PRESSING BUTTON ADJACENT TO PLUG. (See figure 8). Water will recede in these latter batteries to assume the correct level. Do not attempt to keep the plug chamber filled.

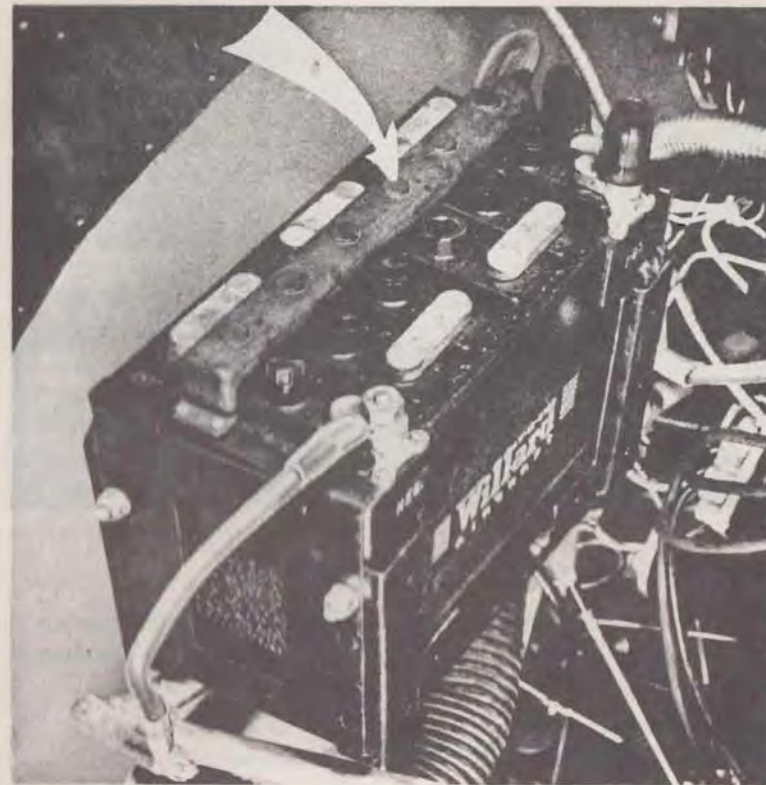

Figure 8—Battery Filling

16. Access to the battery when located under the pilot's seat is gained by lifting seat. Slide pilot's seat forward as far as possible and slide right seat aft as far as possible. Remove the Phillips head screw that attaches the seat cover to the base. Remove the seat stop bolt, illustrated in figure 9. Slide seat full forward after removing bolt and lift on front edge of cushion. Seat will tip up and aft permitting access to the battery.

BRAKE SERVICE

17. The brake system should be replenished with petroleum base hydraulic fluid, Specification No. AN-VV-O-366b, at every 100 hour inspection period. Two master brake cylinders are used, one being

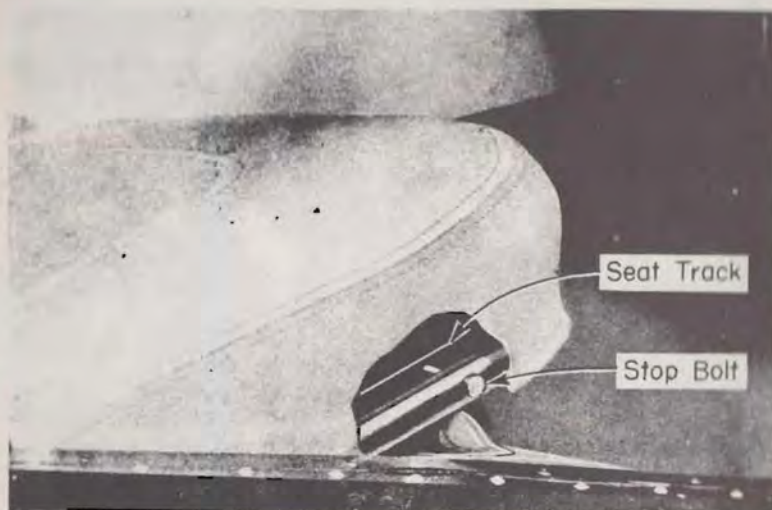

Figure 9—Seat Track Stop Bolt

mounted on each of the pilot's rudder pedals. The fluid reservoir is contained in the master cylinders and the filler plugs are mounted at the top. Brake bleeding and refilling is described in Chapter V.

SHOCK ABSORBER SERVICE

18. The shock absorber strut on each landing gear leg should be replenished with petroleum base hydraulic fluid, Specification AN-VV-O-366b, at every 100 hour inspection period. Always replenish the strut with the weight of the airplane on the wheels.

19. To refill the strut, remove the filler plug at the top of the piston and the oil level plug near the top of the cylinder. Add hydraulic fluid *slowly* until fluid flows out of the oil level hole. To ascertain that the passage is not clogged, run a wire through the oil level hole. Do not replace the oil level plug and the filler plug until the flow of fluid has stopped.

20. Access to the shock absorbers is gained by lifting the front seats as described in paragraph 16 of this chapter, and removing the cover from underneath the seats.



Figure 10—Oil Filler and Dip Stick

REFUELING

21. The airplane is equipped with two fuel tanks, one in each wing. The tanks in the models 108, -1 and -2 hold 20 gallons of fuel each. After refilling these tanks replace the filler cap with the vent tube pointing forward. Aviation Grade 80, unleaded, fuel is recommended.

22. The fuel tanks in the model 108-3 hold 25 gallons of fuel each. These tanks have a separate vent and the caps seal air-tight.

ENGINE OIL

23. The supply of engine oil in the crankcase should be maintained at 8 quarts in the 150 horsepower engines and 9 quarts in the 165 horsepower engines. The oil should be changed after every 25 hours of operation. The use of SAE 40 oil is recommended for temperatures above 40 degrees Fahrenheit and SAE 20 oil is recommended for temperatures below 40 degrees Fahrenheit.

24. The oil filler cap and dip stick are illustrated in figure 10. The oil drain valve, used on airplanes starting with serial number 1210, is illustrated in figure 11. Be sure to install safety wire on this drain valve.

LUBRICATION

25. To facilitate the servicing of these airplanes, charts are provided

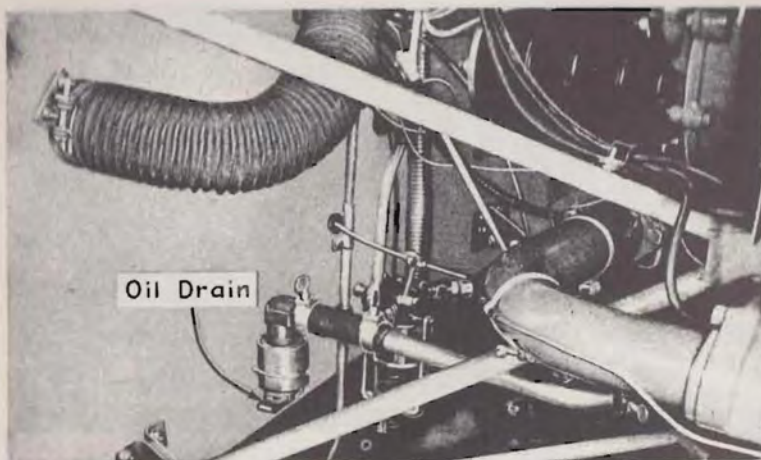

Figure 11—Oil Drain

to indicate the units that require lubrication at intervals of 25, 50, and 100 hours. These charts, figures 13 to 17 inclusive, also give the recommended methods of application. Many of the usual lubrication points have been eliminated by the use of sealed, prelubricated bearings.

26. The following lubricants are recommended:

<i>Lubricant</i>	<i>Specification</i>	
Engine Oil	Above 40°F	SAE 40
	Below 40°F	SAE 20
General Purpose, Low Temperature Oil	AN-O-6a (Army-Navy)	
General Purpose Grease	AN-G-15 (Army-Navy)	
Hydraulic Fluid (Petroleum Base) ...	AN-VV-O-366b (Army-Navy)	

NOTE

Most oil companies and many airports have conversion tables showing the commercial equivalent for Army-Navy lubricant specifications.

27. Lubricate engine controls and flight control cable ends as required to keep the connections from becoming frozen.

LUBRICATION CHARTS

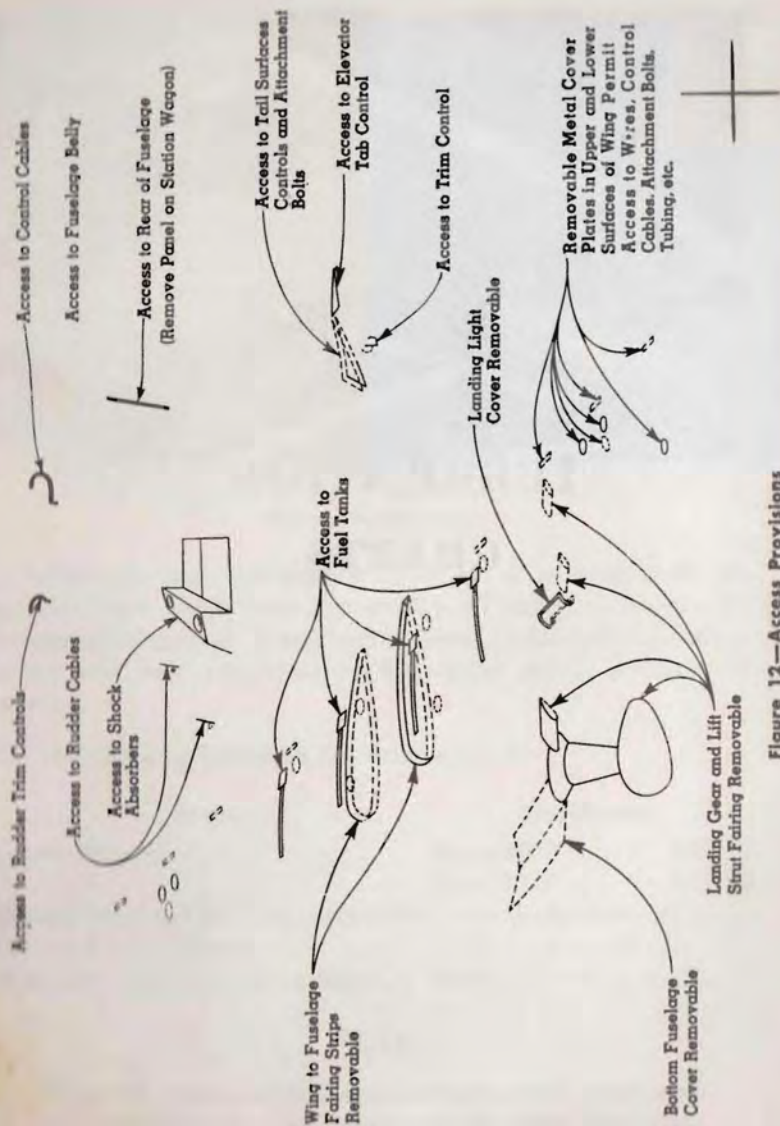
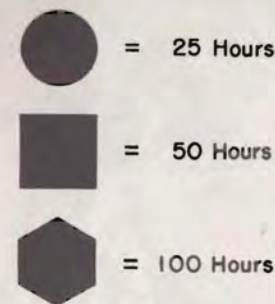

Figure 12—Access Provisions

SYMBOLS USED IN LUBRICATION CHARTS

The following symbols are used in lubrication charts to indicate the operational periods at which various parts of the airplane require lubrication:



The following symbols indicate the method of application and the type of lubricant to be used at the intervals specified above:

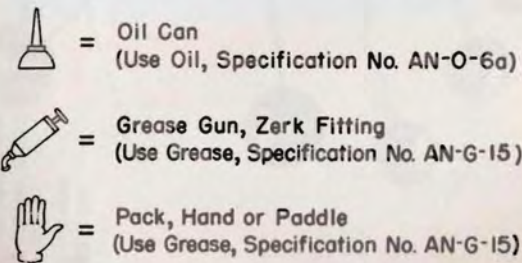

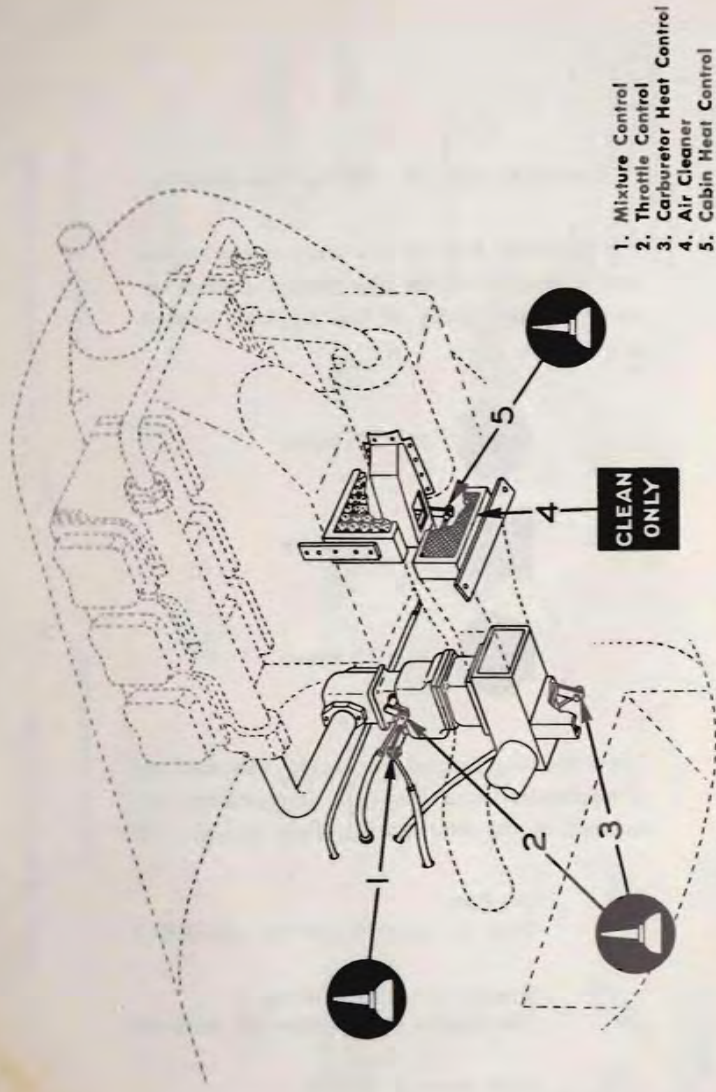

1. Mixture Control
2. Throttle Control
3. Carburetor Heat Control
4. Air Cleaner
5. Cabin Heat Control

Figure 13—Power Plant Lubrication Points

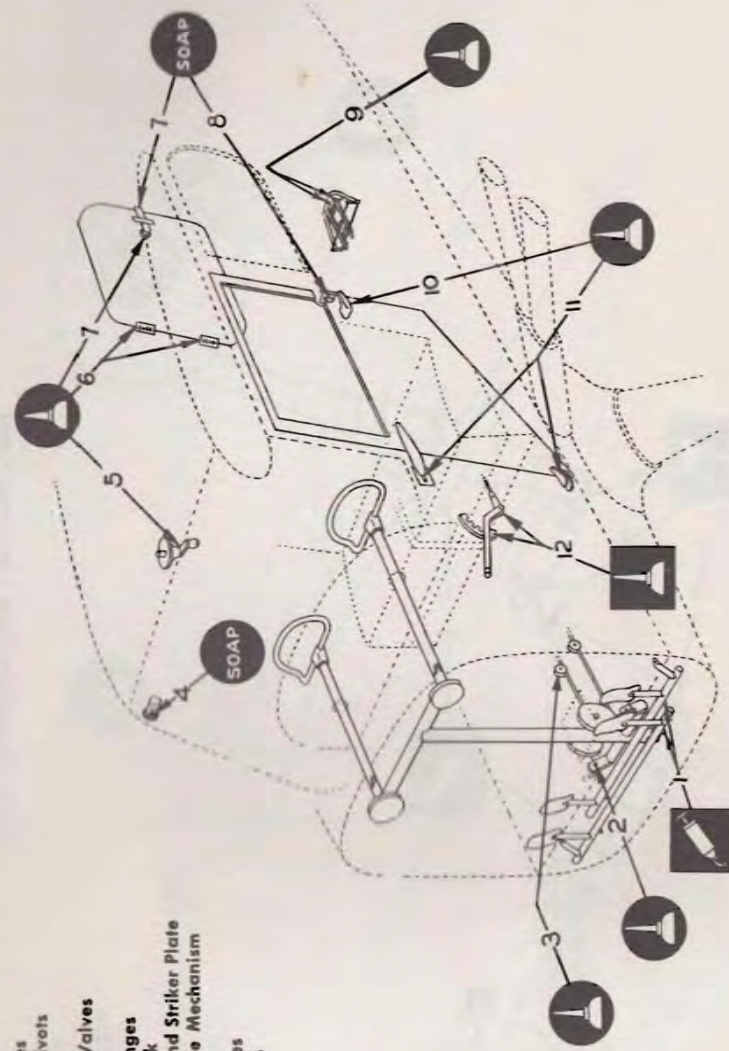

1. Brake Torque Tubes
2. Control Column Pivots
3. Aileron Pulleys
4. Cabin Ventilator Valves
5. Trim Tab Control
6. Baggage Door Hinges
7. Baggage Door Lock
8. Cabin Door Lock and Striker Plate (Model 108-2)
9. Rudder Trim Bungee Mechanism
10. Cabin Door Handles
11. Cabin Door Hinges
12. Flap Lever Pivot

Figure 14—Cabin Lubrication Points

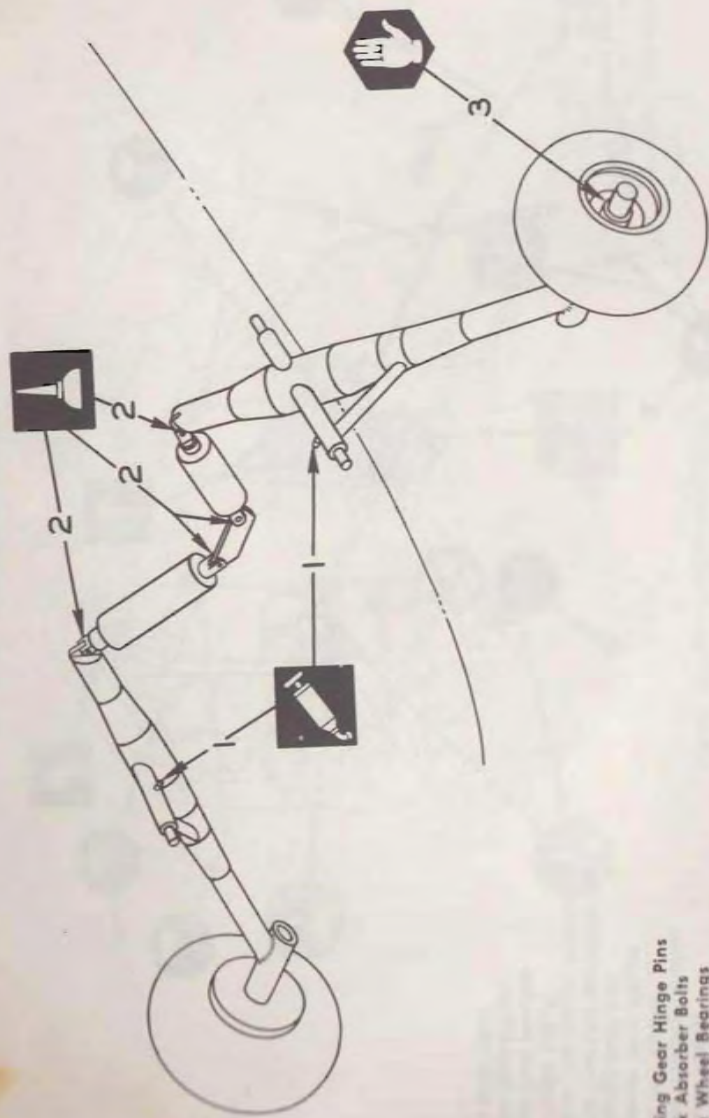

1. Landing Gear Hinge Pins
2. Shock Absorber Bolts
3. Main Wheel Bearings

Figure 15—Landing Gear Lubrication Points

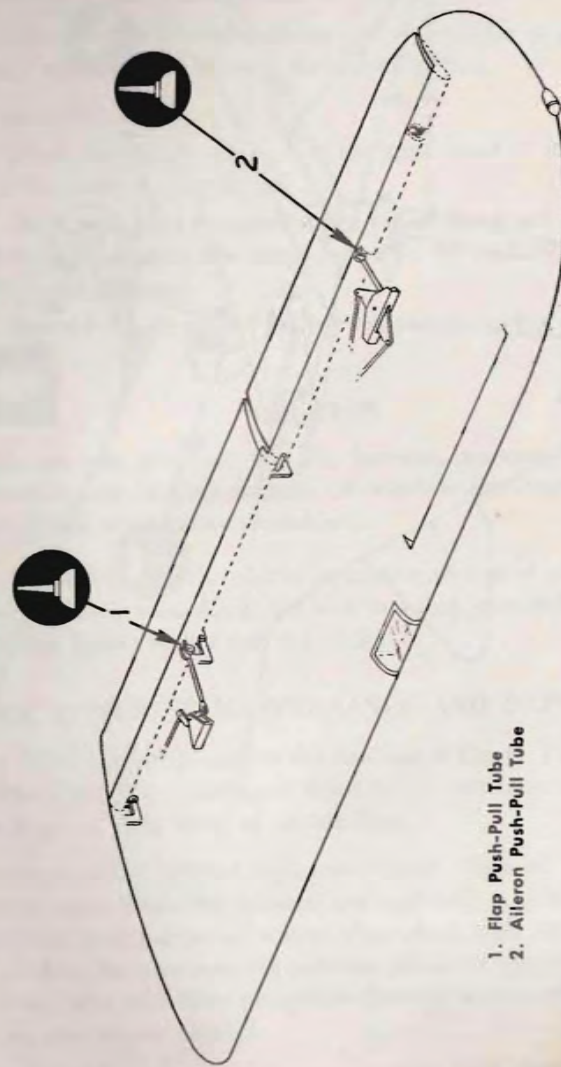

1. Flap Push-Pull Tube
2. Aileron Push-Pull Tube

Figure 16—Wing Lubrication Points



Figure 17—Empennage Lubrication Points

1. Rudder Trim Tab Control and Screw
2. Elevator Trim Tab Control and Screw
3. Elevator Trim Tab Hinge
4. Tail Wheel Knuckle
5. Tail Wheel Bearings
6. Rudder Trim Tab Mechanism

CHAPTER III AIRFRAME STRUCTURE

WINDOWS AND WINDSHIELD CARE

1. The windows and windshields are either Plexiglas or acetate plastic. Early model airplanes used the acetate panels.

2. To clean these Panels:

(a) Flush with clean water. Use the bare hand to dislodge dirt. Be sure the water is free of grit.

(b) Wash with mild soap and warm water. Use a soft cloth, chambray, or sponge to apply the soapy water to the surface, but *do not rub* the plastic surface.

(c) Remove oil, grease, or sealing compounds with a cloth soaked in kerosene.

CAUTION

Do not use gasoline, alcohol, benzene, acetone, carbon tetrachloride lacquer thinner, or window cleaning sprays on plastic windows or windshields.

3. After cleaning, wax the plastic surfaces with a good grade of commercial polishing wax. Apply the wax in a thin even coat and polish by rubbing lightly with a soft dry cloth.

FABRIC COVERING MAINTENANCE AND REPAIR

4. The fabric covering used on the fuselage is Grade A airplane fabric. After the fabric covering is fitted to the air-frame structure the fabric is given eight coats of nitrate dope.

5. To preserve the original high luster finish, clean all gasoline, oil, or grease spots from the finished surfaces with a mild solution of castile soap and lukewarm water; then rinse with clean water. If black carbon deposits from the exhaust cannot be removed with soap and water, use a trisodium phosphate cleaning compound. *Do not use gasoline, acetone, or alcohol.*

6. Restore the lustre with lacquer cleaner, and polish with wax. Avoid rubbing too hard on covering adjacent to or over structural members, sharp points, or edges.

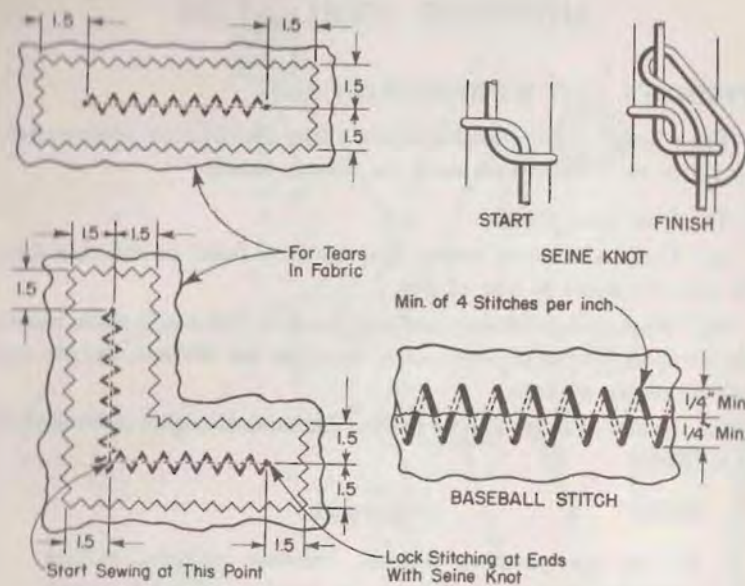

Figure 18—Fabric Repair Methods

7. Repair fabric tears by sewing and applying a patch over the mended area. Do not apply a cemented patch over an unsewn tear longer than 6 inches. Mend a tear as follows (refer to figure 18):

(a) Sew the tear with a single strand of No. 8, four-ply cotton hand sewing thread. Use a curved needle and sew a baseball stitch.

(b) As the stitches are made draw the edges of tear together snugly, but do not pull the thread tight.

(c) After the tear has been sewn, clean an area at least $1\frac{1}{2}$ inches to each side of and beyond each end of the tear with a cloth dipped in nitrate dope, or dope solvent.

CAUTION

Do not allow the cleaning substance to drip through the hole, which is being mended, to the opposite side of the fabric covering.

(d) Wipe the cleaned area with a dry cloth.

(e) Cut a patch of $2\frac{1}{4}$ inch pinked finishing tape long enough to extend an inch beyond either end of the tear.

(f) Apply one brush coat of clear dope to the area around the tear, and press the patch into position. Make certain that all patch edges are stuck down firmly.

(g) Apply one brush coat of clear dope over the patched area. Allow the coat to dry, then apply two more coats of clear dope and two coats of pigmented dope, colored to match the surrounding fabric.

8. Do not attempt to patch large holes, but instead, replace the section of the fabric affected.

9. To repair small holes first cut a rectangular or a triangular hole around the ragged hole and remove the torn fabric. It is easier to sew seams along straight edges. Cut the patch at least four inches larger in every dimension than the hole to be covered, so that the patch extends two inches beyond the trimmed edges of the hole on every side. The mending procedure is the same as that described in paragraph 7.

10. Access holes in the fabric covering of the wing and fuselage are reinforced with nitrate rings. Where holes are cut inside these rings at the factory, the holes are closed with metal covers having spring clips, so that they can be removed or pushed back into place. In addition to the regular access hole (refer to figure 12), additional reinforcement rings have been placed in the fabric cover at points where access holes are likely to be needed. It is permissible to cut an access hole in the fabric in the center of any of these rings. The hole can be closed either with a doped patch (without stitching) or with one of the metal covers used for the regular access holes. If it is necessary to gain access to a place where neither a regular access hole nor a reinforcement ring is provided, a V-shaped slit may be cut in the fabric, with the point of the V forward. The fabric will then fold back, leaving a triangular hole for access. To close the hole, sew up the slit and put a patch over the seam. Use the procedure described in paragraph 7.

FUSELAGE

11. The fuselage frame is made of welded chrome-molybdenum steel tubing. The engine mount frame is a separate bolted on unit, also of chromemolybdenum steel tubing. The fuselage structure is illustrated in figures 19 and 20.

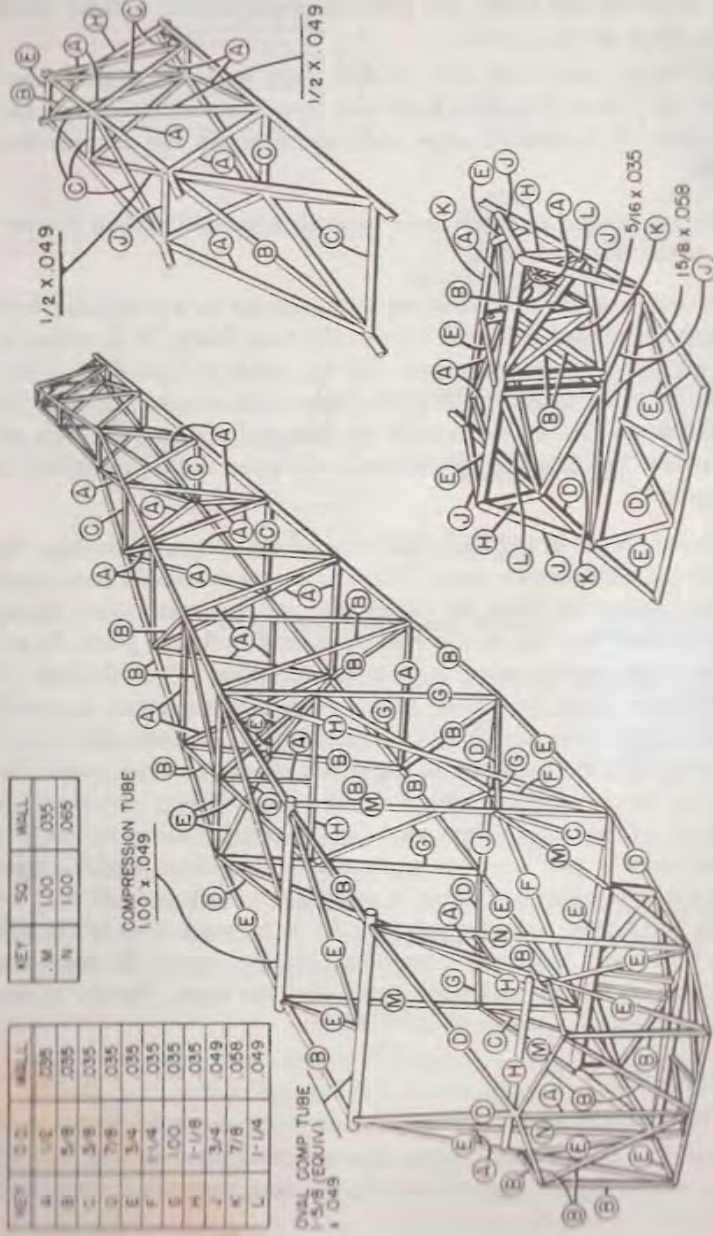

Figure 19—Fuselage Structure (Models 108, -1, -2)

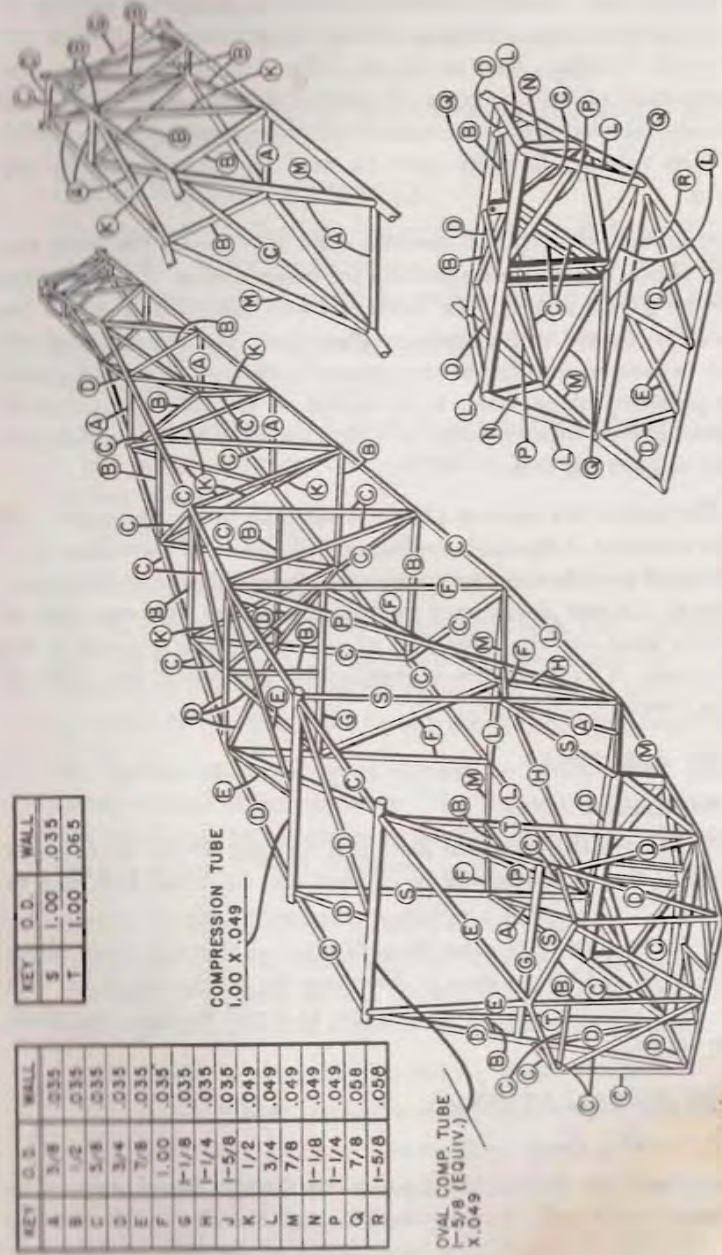

Figure 20—Fuselage Structure (Model 108-3)

12. Repairs may be made to the steel tube structure by welding in the approved manner. Welding during manufacture is of both arc and torch welding. Because of the difference in appearance, the identification of the two types of welding should not be difficult. It is not recommended that arc welded joints be repaired by gas welding. Arc welding, however, may be used on joints originally gas welded.

13. A firewall of corrosion-resistant sheet steel covers the front end of the fuselage frame and separates the cabin section of the fuselage from the engine section. The fuselage frame immediately aft of the firewall is covered with aluminum alloy sheet. The remainder of the frame is covered with fabric impregnated with clear dope and coated with pigmented dope. Refer to paragraph 4. The fuselage contour is maintained by a superstructure of aluminum alloy bows and stringers which support the fabric.

14. The curved transparent plastic windshield forms the upper half of the front end of the cabin enclosure. Two doors of aluminum alloy sheet metal provide entrance to the cabin from either side. The upper halves of the two doors have two piece windows, the rear half of which is fixed and the front half of which slides in grooves in the door frame. A fixed window is installed in each side of the cabin aft of the doors.

DOOR REMOVAL

15. To remove a door:

(a) Remove the small sill plate just forward of the door, inside the cabin. The top hinge will be exposed and the hinge bolt may be removed.

(b) Pull top of door away from fuselage so that top hinge clears the fuselage, and lift the door to disengage the bottom hinge pin. Lift door as nearly straight up as possible to avoid bending the lower hinge support.

DOOR INSTALLATION

16. To install a door:

(a) Insert the bottom hinge pin in the bottom hinge support on the fuselage and push the top hinge through the slot in the fuselage skin. Align the hole in the top hinge fitting of the door with the hole

in the fitting welded to the fuselage structure.

(b) Insert the hinge clevis pin and install a cotter pin. Early airplanes use a bolt, castellated nut, and cotter pin.

(c) Install still plate on inside of cabin. This plate is secured with steel metal screws.

DOOR WINDOW REMOVAL

17. The door windows are removed by taking off the molding around the window frame on the inside of the door. The rear fixed panel must be removed before the forward panel can be taken out.

DOOR WINDOW INSTALLATION

18. To install the door windows:

(a) Install fabric channel on front panel and position in frame.

(b) Install rear panel. When sealing is required, use Alumilastic sealing compound.

(c) Install molding.

REAR CABIN WINDOW REMOVAL

19. To remove a rear cabin window in models 108, 108-1 and 108-2, take out the screws from the retainer strips around the edges of the window on the outside of the cabin and remove strips. It may be necessary to pry the panel loose from the sealing compound.

20. To remove a rear cabin window in model 108-3, pry out the center portion of the rubber molding on the outside of the window. The panel and the remainder of the rubber molding will then be free enough to permit their removal.

REAR CABIN WINDOW INSTALLATION

21. To install a rear cabin window in models 108, 108-1 and 108-2, coat edge of fuselage around window opening with Alumilastic sealing compound, position window, and install retainer strips.

22. To install a rear cabin window in model 108-3:

(a) Install rubber channel molding. Use special tool No. 756460.

(b) Insert window panel into molding.

(c) Install filler strip into rubber channel molding. Use special tool No. 756475. Do not install insert so that joint coincides with joint in channel.

WINDSHIELD REMOVAL

23. To remove either panel of the windshield:

- (a) Take out the screws in the upper wing to fuselage gap strip on the side of the fuselage that the panel is to be removed from. Bend gap strip up away from the windshield.
- (b) Remove retainer across top of windshield.
- (c) Remove retainer down center post of windshield.
- (d) Remove retainer down door post at the side of windshield.
- (e) Lift panel up and aft out of molding around top of cowl.

WINDSHIELD INSTALLATION

24. Before installing a windshield panel be sure that all surfaces of contact are clean and free of old cement and dirt. Clean out groove in extruded molding extending across the top of cowl. To install a windshield:

- (a) Coat inside groove of extruded molding with Alumilastic sealing compound.
- (b) Attach strips of Chrom-seal tape 0.025 inch thick by 0.50 inch wide, to center post, cabin ceiling cross member, and door post, using Alumilastic sealing compound to glue the strip in place.
- (c) Coat Chrom-seal strips with Alumilastic sealing compound and install windshield panel. Position felt block at upper outer corner of panel at wing leading edge.
- (d) Glue Chrom-seal tape over windshield, under retainers, with Alumilastic sealing compound.
- (e) Coat Chrom-seal tape with Alumilastic sealing compound and install retainers around windshield panel.
- (f) Secure wing gap strip cover around leading edge of wing.

WING

25. The wings are joined to the top of the fuselage structure at each side with two bolts. Each wing is composed of two aluminum alloy spars with stamped aluminum alloy ribs riveted thereto. The leading edge of each wing is slotted at the outboard ends. The wing slots and the wing tips are bolted to the main wing structure and are removable. The flaps and ailerons each attach to the wing panels with three hinge bolts and a control arm. The inboard end of each wing panel contains a fuel tank. The pitot-static tubes are near the outboard end of the slot in the leading edge of the left wing. The two landing lights

are in the leading edge of the left wing just inboard of the slot. Ventilator intake screens are located in the leading edges at the root of each panel. A red position light is located in the left wing tip and a green position light is located in the right wing tip.

26. The wings (and ailerons on airplanes prior to the model 108-3) are covered with fabric and are coated with pigmented nitrate dope. (Refer to paragraphs 4 through 10 of this chapter.) Removable access covers are provided in the fabric at all points where it is necessary to gain access to parts for removal, installation, or maintenance. Additional fabric reinforcement rings, for the installation of removable covers, are provided at other locations for use if more access holes are needed.

27. Each wing is braced with two aluminum alloy lift struts. The two lift struts are separated where they attach to the under surface of the wing, but come together where they attach to the fuselage. The lower end of the front strut attaches to the fuselage, and the lower end of the rear strut attaches to the front strut. The length of the rear lift strut is adjustable by means of the lower eyebolt, so that the wing can be warped slightly to improve its aerodynamic characteristics. (Refer to paragraph 29 d, e this chapter.)

WING PANEL REMOVAL

28. The approximate weight of a wing panel, complete with flap and aileron, is 110 pounds. To remove either wing panel:

- (a) Drain all fuel from the wing tank.
- (b) Remove gap strips that cover between the wing and the fuselage.
- (c) Remove the metal fairings around the upper and lower ends of the lift struts.
- (d) In the gap between the wing and fuselage disconnect the wiring, fuel line, and pitot-static lines. Leave fuel line hose on fuselage, disconnecting the clamp from the wing fitting.
- (e) In the cabin remove rear seats and, in the Station Wagon airplanes, take out the rear panel of the cabin. Disconnect the aileron cables and remove the pulleys on the upper fuselage cross tube to allow the cable ends to be pulled over the cabin headlining and hence free of the cabin.
- (f) Use the slide zipper fastener to open the rear access hole in the cabin ceiling and disconnect the flap cables. Pulling down on the

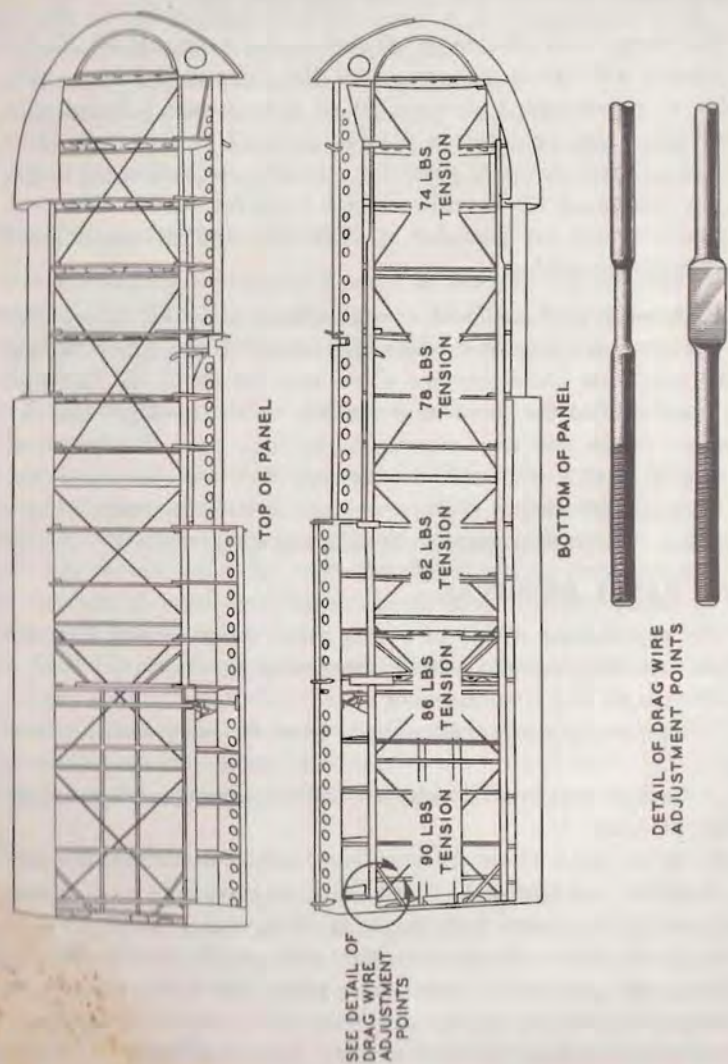

Figure 21—Wing Drag Wires

flap trailing edge will slacken these cables so that the turnbuckles will not have to be disassembled.

(g) Disconnect the aileron idler cable through the rear access hole in the cabin ceiling. A fairlead at the fuselage match rib must be removed before this cable may be pulled free.

(h) Remove the ventilator valve assembly, located inside the cabin in line with the wing leading edge.

(i) Support the wing at the outboard end with a temporary structure capable of bearing the weight and then remove the lift struts.

(j) Remove the wing-to-fuselage bolts. A long-extension socket wrench, permitting turning the bolts from in front, or behind, the wing will facilitate removing these bolts. Pull wing straight out from fuselage until clear.

NOTE

Do not raise or lower wing tip with wing root attachment bolts installed.

WING PANEL INSTALLATION

29. To install a wing panel:

(a) Raise wing panel to the proper height and about one foot from fuselage. Thread control cables into fuselage, installing the aileron idler cable (the lower of the most forward cables) through fairlead in fuselage. Pull cables into cabin ceiling through zipper openings.

(b) Swing wing straight into proper position on fuselage fittings and attach with bolts. The rear wing fitting should be drawn up tight to clamp the fuselage fitting. Do not bend wing fitting. If gap exists, fill with washers before drawing up on nut. Front fuselage fitting may float in wing fitting. Do not turn nut down so that wing fitting is bent or distorted.

(c) Install front lift strut. After installing this strut, support for the wing panel may be removed.

(d) Install the upper end of the rear lift strut to the wing fitting. Adjust the eyebolt in the bottom of the rear lift strut so that the eye registers with the bolt hole in the lower end of the front strut when the bottom surfaces of the wing ribs at the root and near the tip are both at the same angle to the thrust line of the fuselage.

(e) When the foregoing preliminary adjustment is completed,

make the final adjustment of the eyebolt by unscrewing the bolt five complete turns. The rear lift strut is then the proper length to warp the wing panel the required amount for best aerodynamic efficiency.

(f) In the wing gap, working from above, connect the fuel line, and pitot-static lines at their hoses. Starting with the model 108-3, a rubber washer is installed on the fuselage fuel line to act as a drip stop in case of a leaking hose connection. Although not mandatory, the addition of this washer to all airplanes when convenient is recommended.

(g) Connect the electrical wiring by pushing terminals together within the plastic case and wrapping and tying the end of the case with cord. Connect wires as follows:

- In right wing connect: Wire No. 33 to No. 34
Wire No. 29 to No. 40
- In left wing connect: Wire No. 36 to No. 37
Wire No. 30 to No. 39
Wire No. 18 to No. 38

Connect wing bonding wire to fuselage.

(h) Connect aileron idler cable in cabin ceiling. This cable is the one that goes straight through the cabin. Adjust turnbuckle so that both aileron trailing edges are simultaneously $\frac{1}{8}$ inch below the flap trailing edges (flaps in UP position).

(i) Thread the aileron cables from the wing through the cabin ceiling so that these two cables may be installed over the oblique pulleys at top center of the rear cabin wall. Take pulleys out of their brackets, wrap cable around them, and reinstall the pulleys.

(j) Assemble turnbuckles behind rear wall and adjust their length so that control wheel is straight when ailerons are neutral. Tighten turnbuckles to obtain a cable tension of from 20 to 25 pounds.

(k) Install flap cable over the pulley in the center of the cabin ceiling by removing and reinstalling the pulley with the cable in place.

(l) Assemble turnbuckle and tighten cable until the single cable in the fuselage has a tension of from 44 to 50 pounds.

(m) Safety all turnbuckles with wire.

(n) Install cabin ventilator assembly into wing from the inside of the cabin.

(o) Install the gap strips over the gap between the fuselage and the wing.

(p) Install the fairing cuffs about the upper and lower ends of the lift struts.

AILERON AND FLAP REMOVAL

30. To remove the aileron or flap from a wing panel disconnect the control rod at the aileron or flap end, take out the three hinge bolts, and pull aileron or flap straight back off wing.

AILERON AND FLAP INSTALLATION

31. To install an aileron or flap align the holes in the hinges with the hangers in the wing and install the hinge bolts. Connect control rod to the aileron or flap.

EMPENNAGE STRUCTURE

32. The following units make up the empennage: fin, rudder stabilizer, elevator, elevator trim tab, and on model 108-3 airplanes, a rudder trim tab. All of these assemblies are completely fabricated from aluminum alloy. The empennage installation is illustrated in figures 22 and 23.

33. The fin is bolted and riveted to the fuselage structure. The stabilizer is bolted to both the fin and the fuselage structure. The rudder is attached to the fin with three hinges. The rudder tab is a fixed portion of the rudder trailing edges in the models 108, 108-1, and 108-2. On the model 108-3 the rudder trim tab is attached to the rudder with a continuous hinge. The elevator is composed of two panels bolted to the elevator control horn at the center and supported near the outboard ends with two hinges attached to the stabilizer. The elevator tab is joined to the left elevator panel with a continuous hinge.

RUDDER REMOVAL

34. On the model 108-3 disconnect the rudder trim tab control from the pulley in the tail of the fuselage. This is accomplished as follows:

(a) Remove the two small access covers at the bottom rear of the fuselage.

(b) Loosen set screw retaining housing for flexible shaft in casting.

(c) Loosen two set screws in pulley hub and pry flexible shaft clear of mechanism.

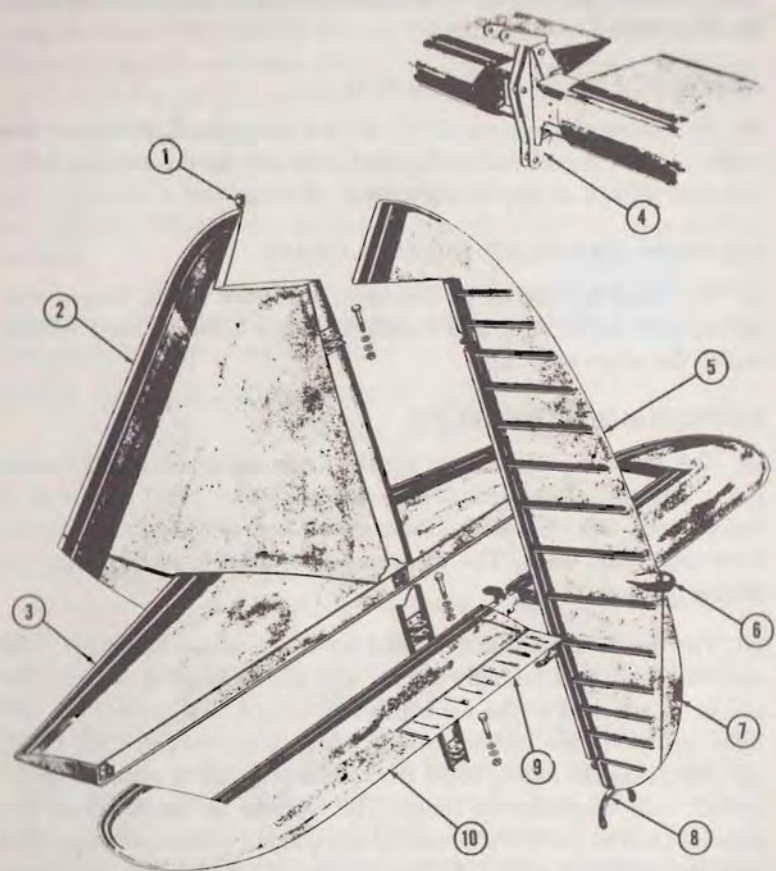

- | | |
|----------------------------|-----------------------------|
| 1. Radio Antenna Clevis | 6. Tail Light |
| 2. Fin | 7. Rudder Fixed Tab |
| 3. Horizontal Stabilizer | 8. Tail Wheel Steering Yoke |
| 4. Detail of Elevator Horn | 9. Elevator Tab |
| 5. Rudder | 10. Elevator |

Figure 22—Empennage Assembly (Models 108, -1, -2)

35. Proceed to remove rudder as follows:

- (a) Disconnect rudder control cables. These cables are spring loaded so that it is not necessary to loosen the turnbuckles.
- (b) Detach tail wheel steering springs.
- (c) Take out the three hinge bolts.

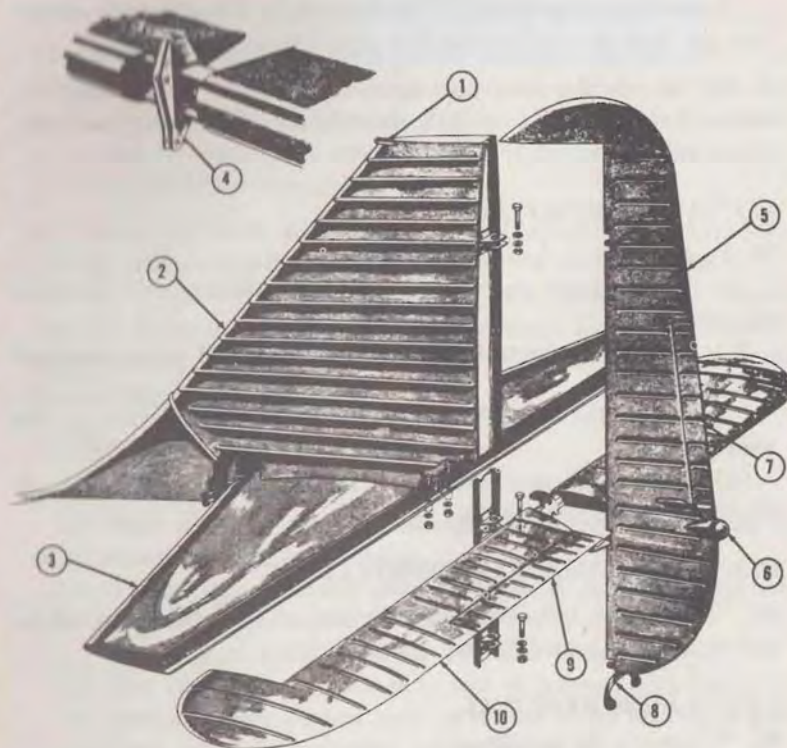

- | | |
|----------------------------|-----------------------------|
| 1. Radio Antenna Clevis | 6. Tail Light |
| 2. Fin | 7. Rudder Tab |
| 3. Horizontal Stabilizer | 8. Tail Wheel Steering Yoke |
| 4. Detail of Elevator Horn | 9. Elevator Tab |
| 5. Rudder | 10. Elevator |

Figure 23—Empennage Assembly (Model 108-3)

(d) Pull rudder aft away from fuselage about 6 inches and disconnect tail light wire.

RUDDER TRIM TAB REMOVAL

36. The rudder trim tab on the Models 108, 108-1 and 108-2 is an integral part of the rudder trailing edge and is not removable. The Model 108-3 is equipped with a controllable rudder trim tab attached to the rudder with a continuous hinge.

37. Remove the controllable rudder trim tab by detaching the control from the horn and pulling the wire from the continuous hinge.

38. To remove the trim tab control mechanism from inside the rudder it is necessary to drill the rivets from housing over the mechanism.

ELEVATOR REMOVAL

39. To remove the elevator panels:

(a) Remove cover on inboard end of left elevator over the trim tab control.

(b) Detach trim control from trim tab horn and from inner end of elevator panel.

(c) Remove the two bolts joining the elevator panels through the control horn.

(d) Remove the two outer hinge bolts and pull elevator panels aft and out from the stabilizer.

ELEVATOR TRIM TAB REMOVAL

40. The elevator trim tab may be taken off the elevator panel by pulling the wire out of the continuous hinge.

STABILIZER REMOVAL

41. To remove the stabilizer:

(a) Remove the elevator according to the procedure described in paragraph 39.

(b) Remove the large access covers on either side of the fuselage just beneath the stabilizer.

(c) Disconnect the elevator control cables from the control horn. The turnbuckles for these cables are located just behind the rear cabin wall. Access may be gained after removing the rear cabin seats and, in the case of the Station Wagon airplanes, the rear wall panel.

(d) Remove the elevator control horn.

(e) Remove the two bolts attaching the stabilizer to the rear of the fuselage.

(f) Remove the four bolts attaching the stabilizer to the front spar of the fin.

(g) Pull up the elevator control cable through stabilizer.

(h) Slide stabilizer out from underneath the fin.

FIN

42. The fin is bolted and riveted to the fuselage structure before the fabric cover is installed. Although replacement of the fin assembly does not come under the heading of General Service, it is possible to remove and install this assembly without recovering the airplane provided the fabric is in good condition.

43. Spray the fabric at the rear of the fuselage with fabric rejuvenator or dope retarder to soften the dope. On the models 108, 108-1, and 108-2 the fabric may be peeled back sufficiently to permit removal of the fin after the tapes and retainers have been removed. On the model 108-3 it will be necessary to cut the fabric along the leading edge of the dorsal fin.

STABILIZER INSTALLATION

44. To install the stabilizer:

(a) Slide stabilizer through fuselage underneath fin carefully to avoid scratching stabilizer surface.

(b) Thread upper elevator cable through the holes in upper and lower surfaces at the center of stabilizer.

(c) Bolt nose of stabilizer to fin with four bolts.

(d) Bolt rear spar of stabilizer to rear of fuselage with two bolts.

(e) Install elevator control horn on central hinge bearing at rear of stabilizer and attach elevator cables thereto.

(f) Tighten elevator cables to a cable tension of from 100 to 110 pounds by use of the turnbuckle located just behind the cabin rear wall.

(g) Install access plates on both sides of fuselage under stabilizer.

ELEVATOR INSTALLATION

45. To install the elevator:

(a) Bolt the inboard ends of the elevator panels to the elevator horn assembly.

(b) Install the two outer hinge bolts. Felt washers should be placed on both sides of the bearing to keep bearing clean.

(c) Attach trim tab control housing to stud on inboard end of left elevator panel. If trim tab is mounted on this panel, connect control clevis to tab control horn.

(d) Install cover over tab control on inboard end of left elevator panel.

ELEVATOR TRIM TAB INSTALLATION

46. To install the elevator tab, line up the half hinge on the tab with half hinge on elevator and insert the hinge wire. Bolt the tab control clevis to the tab control horn.

RUDDER INSTALLATION

47. To install the rudder:

(a) When positioning rudder on its bearings, thread tail light wire and, on airplanes with controllable rudder trim tab, trim control shaft through rubber grommets at rear of fuselage. Join wires inside plastic case and tie end of case with cord.

(b) Suspend the rudder on its hinges and install hinge bolts. Felt washers should be placed on both sides of the bearings to keep bearings clean.

(c) Connect rudder cables. These cables are spring loaded and thus it is not necessary to slacken the turnbuckles so as to attach them.

(d) Attach tail wheel steering springs.

(e) Set rudder trim tab control, in cabin, in neutral and set tab on rudder so that trailing edge is in line with rudder trailing edge.

(f) Install end of flexible shaft in mechanism for rudder trim tab in rear end of fuselage. Secure shaft in pulley by tightening the two set screws. Secure shaft housing in casting by tightening.

(g) Secure shaft housing in casting by tightening bolt.

RUDDER TRIM TAB INSTALLATION

48. If rudder trim tab is not attached to the rudder, install tab as follows:

(a) Line up the half hinge on the tab with half hinge on rudder and insert the hinge wire.

(b) Bolt tab control clevis to the tab control horn.

(c) Proceed with connection and rigging of tab control as outlined in parts e, f, and g, of the preceding paragraph.

CHAPTER IV

CONTROL SYSTEMS

GENERAL

1. Movable control surfaces on the Stinson model 108 series airplanes include ailerons, elevator, rudder, flaps, elevator trim tab, and on the model 108-3, a rudder trim tab.

CABLES

2. Cables are used in all control systems. In the elevator system, however, the control column at the front of the cabin is connected to a bell crank at the rear of the cabin with a push pull tube running under the cabin floor. Cables connect the bell crank to the elevator horn.

3. The following are recommended rigging loads for control cables:

CABLE TENSION TABLE

<i>Surface</i>	<i>Rigging Load</i>
Aileron.....	20 to 25 pounds
Flaps (Up position).....	44 to 50 pounds
Elevator.....	100 to 110 pounds
Elevator Trim Tab.....	10 to 20 pounds
Rudder Trim Tab.....	3 to 7 pounds

CONTROL SURFACES TRAVEL

4. Control surface travels are limited by positive stops, located so as to preclude the possibility of the controls passing dead center and locking. Only the elevator and flap control stops are adjustable. If necessary, the remainder of the stops can be filed or shimmed to adjust surface travel. The elevator system has a stop on the push-pull tube that contacts the lower arm of the flap control lever assembly and limits the up-travel of the elevators when the flaps are up. Another adjustable stop on the control column is designed to hit the fuselage cross tube supporting the instrument panel and thus limit the up travel cushion of the control wheel shaft when the flaps are down. The flaps have adjustable stops at the wing bell cranks. These stops can be used to align the flap and wing trailing edges when the flaps are up.

5. Travel of control surfaces in degrees and inches is shown in the following table. The measurement in inches is the straight line distance at the trailing edge of the surface.

CONTROL SURFACE TRAVEL

Surface	Degrees	Inches
Ailerons—Up	23 to 25	4.80 to 5.20
—Down	11 to 13	2.33 to 2.73
Flaps—Intermediate	26 to 28	4.10 to 4.40
—Full Down.....	32 to 34	6.00 to 6.30
Rudder—Left	18½ to 19½	4.77 to 5.03
—Right	18½ to 19½	4.77 to 5.03
Elevator (Flaps Up)—Up.....	16½ to 17½	4.88 to 5.18
—Down	19½ to 20½	6.09 to 6.41
(Flaps Down)—Up	25 to 26	7.80 to 8.10
—Down	19½ to 20½	6.90 to 6.41
Elevator Trim Tab (Models 108, 108-1, and 108-2)—Up	14 to 15	1.13 to 1.22
—Down	14 to 15	1.13 to 1.22
Elevator Trim Tab (Model 108-3)		
—Up 21 to 22	1.75 to 1.84	
—Down 14 to 15	1.13 to 1.22	
Rudder Trim Tab—Right	17 to 19	1.04 to 1.22
—Left	17 to 19	1.04 to 1.22

*Ailerons are in neutral position when the inboard end of the trailing edges are one-eighth of an inch below the flap trailing edges (Flaps up position).

The rudder is in neutral position when it is aligned with the fin. Rudder movement in inches is measured at the trailing edge in line with neutral elevator.

Elevator is in neutral position when leading edge of overhang is .31 inches below leading edge of stabilizer on airplanes serial No. 1 to 496. On airplanes starting with Serial No. 496 and up, the elevator leading edge is .50 inches below the stabilizer leading edge when the elevator is in neutral. Movement of the elevator in inches is measured at the trailing edge intersection with the rudder. The elevator cables should be rigged with flaps down and be so adjusted that the elevator control horn stops engage before the stops on the control column make contact.

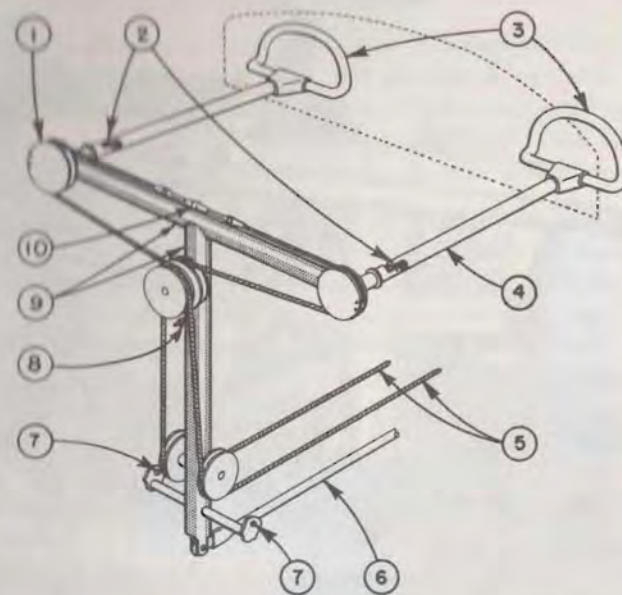

- | | |
|-------------------------|----------------------------|
| 1. Aileron Drive Pulley | 6. Elevator Push-Pull Tube |
| 2. Universal Fittings | 7. Pivot Bearings |
| 3. Control Wheels | 8. Stop Bolt |
| 4. Control Shaft | 9. Control Column Yoke |
| 5. Aileron Cables | 10. Tumbuckle |

Figure 24—Control Column Assembly

CONTROL SYSTEMS MAINTENANCE

6. Only mechanics licensed by the Civil Aeronautics Administration are permitted to overhaul or rig control surface systems. All systems should be inspected at regular intervals. Cables that are worn or frayed to the extent that an operating hazard is presented should be replaced. Check the condition of all pulleys and pulley brackets in each system. Test the security of all cable connections and all connections at push-pull tubes, at bell cranks, and at control horns. Remove any loose parts, such as nuts, bolts, or washers that are near pulleys or other control units. For lubrication requirements for surface controls, refer to the lubrication charts in Chapter II.

CONTROL COLUMN

7. The control column, which is illustrated in figure 24, operates

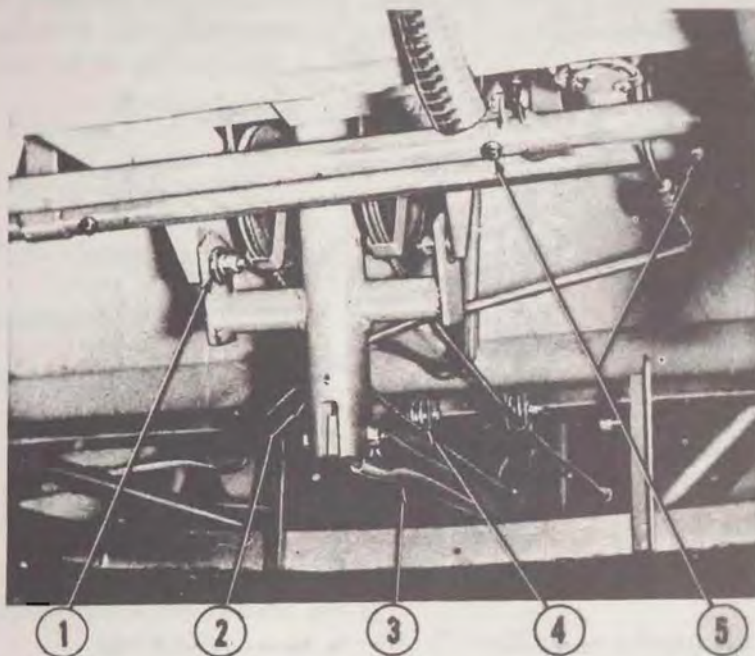

- | | |
|------------------------------------|----------------------------|
| 1. Control Column Pivot Bearing | 3. Elevator Push-Pull Tube |
| 2. Control Column | 4. Aileron Metal Pulleys |
| 5. Brake Mechanism Grease Fittings | |

Figure 25—Controls Under Pilot's Floor

the ailerons and elevator. The dual control wheels are mounted to steel tubular shafts which project through the instrument panel. The control shafts slide through bushings in the supports at the instrument panel. The aileron system is connected to the control shafts by universal joints. When the elevator is raised or lowered, the lower end of the control column yoke pivots on two bearing supports (refer to figure 25).

8. If the right wheel is not required, it can be removed from the airplane. To remove it, disconnect the shaft from the universal fitting and pull the shaft and wheel assembly through the dash. The bolts should not be replaced in the universal joint because they may interfere with full elevator travel by striking surrounding structure.

ELEVATOR CONTROL SYSTEM

9. The elevator is made in two panels, bolted together in the center. As illustrated in figure 26, the elevator is operated through the control column. The control column yoke is connected to a bell crank with a push-pull tube. Cables connect the bell crank to the elevator horn. There are no pulleys in the elevator system.

10. When the flaps are up, the up-travel of the elevator is limited by a stop on the push-pull tube which engages the lower arm of the flap lever. Elevator down-travel, and up-travel when flaps are down, is limited by stops built into the elevator control horn. Cushion stops on the control column prevent overloading the elevator control system by excessive movement of the control shafts when the elevator limit stops are engaged.

ELEVATOR CONTROL SYSTEM ADJUSTMENT

11. Elevator travel can be increased to meet the requirements of paragraph 5 by filing the stop plates on the stabilizer. To decrease travel it is necessary to install tapered shims on elevator center hinge fitting, under the control horn. Cushion stops on the control column should be adjusted to give 0.00 to 0.38 inch clearance at the front stop, and 0.38 to 0.75 inch clearance at the rear stop when the elevator horn is stopped.

12. Cable tension and alignment of control column cushion stops is controlled by turnbuckles located just aft of the rear cabin wall. Access to these turnbuckles is gained by removing the rear seats and opening rear cabin wall, or taking out rear panel of Station Wagon airplanes. Elevator cables should be tightened to a tension of 100 to 110 pounds. Safety turnbuckles with new wire after adjustment is completed.

AILERON CONTROL SYSTEM

13. The ailerons, as illustrated in figure 27, can be operated by either of the dual wheels on the control column. Cables routed aft from the control column pass through two forward pulleys, two fairleads, and two aft pulleys under the floor of the cabin. The fuselage cables are connected to the wing aileron cables by two turnbuckles located behind the rear cabin wall. The cables leading to the aft arms of bell cranks in each wing panel, pass through two pulleys in the top of the cabin, a pulley at each wing and fuselage inter-

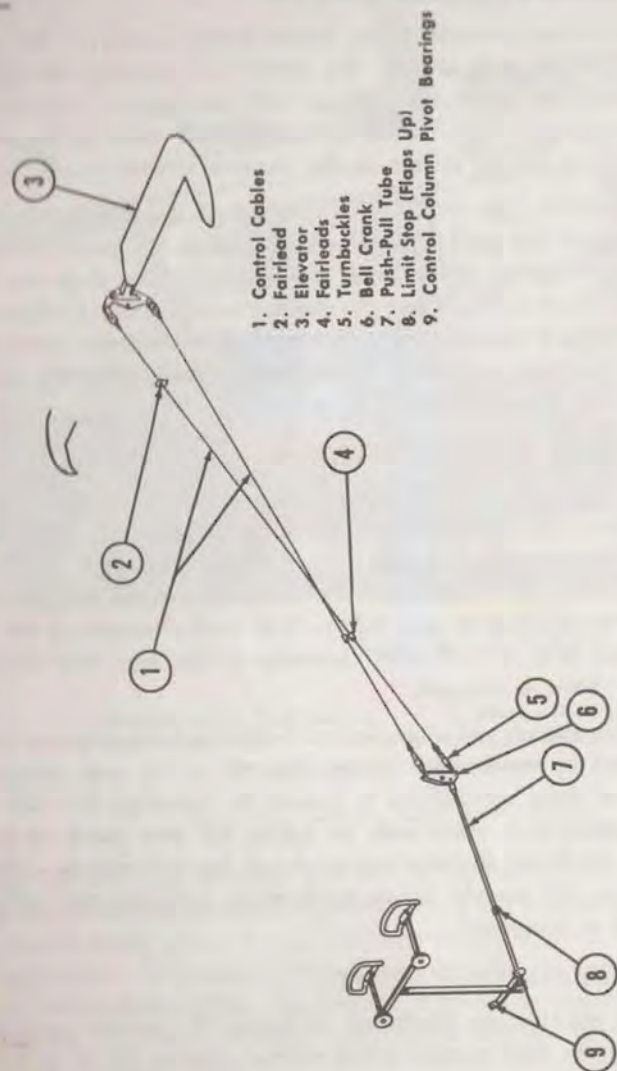

section, and pulleys inboard of each bell crank. The forward arms of the left and right wing bell cranks are connected by an idler cable. This cable passes through pulleys on each wing rear spar and through a pulley centered in the top of the cabin. The idler cable is connected on the right side of the pulley by a turnbuckle and on the left side by a clevis fitting.

AILERON CONTROL SYSTEM ADJUSTMENT

14. Proper adjustment of the aileron control system will usually result in manipulation of all four turnbuckles. The control wheels are aligned by adjustment of the turnbuckle on the forward end of the control column. Symmetry of the two aileron trailing edges is obtained by adjustment of the turnbuckle in the idler cable, located in the cabin ceiling and accessible through the rear headlining zipper and by adjustment of the two turnbuckles aft of the rear cabin wall. Correct tension for aileron cables is 20 to 25 pounds. Refer to paragraph 5 for correct travels. Safety turnbuckles with new wire after adjustment is completed.

15. Aileron neutral position may be easily secured in model 108-3 airplanes by aligning hole in cast bell crank in wing panel with hole in bell crank support and inserting a pin to maintain neutral while adjusting cables. This positioning device is accessible through the access hole in the bottom of the wing just forward of the aileron center hinge.

LATERAL TRIM

16. Each aileron is provided with a fixed trim tab at the inboard end of its trailing edge. It is permissible to bend either tab 26 degrees up or down to correct the lateral attitude of the airplane.

FLAP CONTROL SYSTEM

17. The flaps are manually operated by a lever located below and between the front seats. This control system is illustrated in figure 23. The flaps are lowered when the lever is pulled up, and raised when lever is pushed down. A three-position lock operated by a thumb pressure button on the end of the lever, locks the flaps in the up, take-off, or landing positions.

18. A cable connected to the flap lever assembly is routed aft and through a pulley under the rear seat, then up through a pulley in

1. Disconnect Link
2. Idler Cable
3. Right Aileron
4. Turnbuckles
5. Push-Pull Tube
6. Left Aileron
7. Bell Crank
8. Fairlead
9. Control-Wheel
10. Forward Pulleys
11. Control Column Yoke

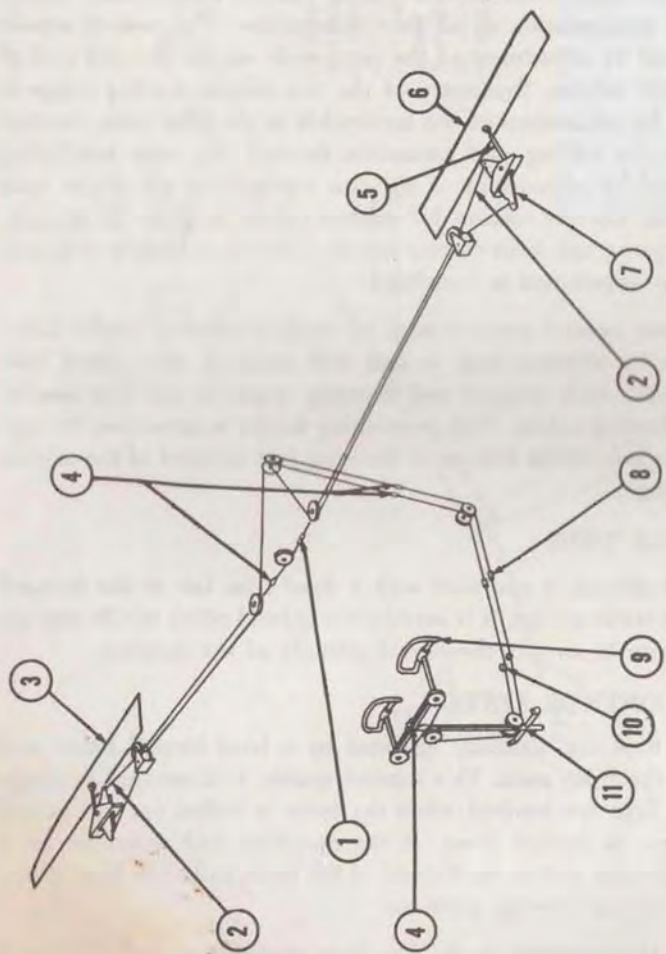
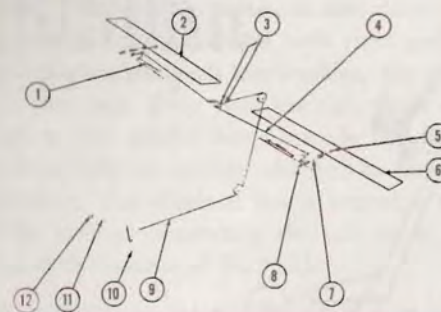

Figure 27—Aileron Control System



- | | |
|------------------|-------------------------------------|
| 1. Return Spring | 7. Push-Pull Tube |
| 2. Right Flap | 8. Adjustable Stop |
| 3. Turnbuckles | 9. Fuselage Cable |
| 4. Wing Cable | 10. Stop on Elevator Push-Pull Tube |
| 5. Control Horn | 11. Control Lever |
| 6. Left Flap | 12. Lock Button |

Figure 28—Flap Control System

the top of the cabin. The fuselage cable is connected to wing cables in the cabin ceiling by turnbuckles. The wing cables pass through two pulleys in the top of the cabin and attach to bell cranks in each wing panel. The bell cranks are connected to the flap control horns by means of push-pull tubes so as to actuate the flaps. A spring returns the flaps to neutral position when the control is released.

FLAP CONTROL SYSTEM ADJUSTMENT

19. When the flaps are in the *up* position, the flap trailing edge can be aligned with the wing by use of the adjustable stops at the bell cranks. Slack in the cables is taken up by the return springs. The rigging load for the flap cable in the fuselage is 44 to 50 pounds. Proper tension in the cables can be obtained by adjustment of the turnbuckles in the cabin ceiling. These turnbuckles are accessible

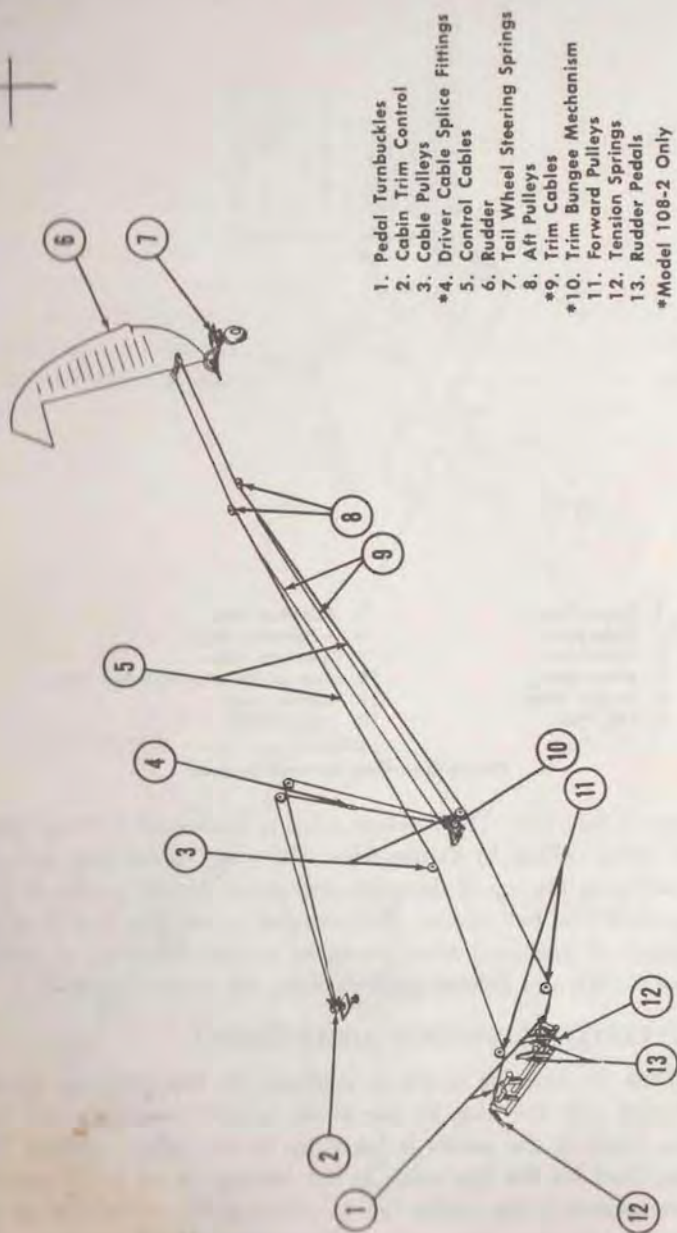

Figure 29—Rudder Control System

through the rear zipper opening in the headlining. For travel limits of the flaps, refer to paragraph 5. If turnbuckles are used to adjust the flap system, be sure that they are safetied with new wire after an adjustment has been made.

RUDDER CONTROL SYSTEM

20. As illustrated in figure 29, the rudder is operated by either of the dual pedal controls. One pedal assembly includes both left pedals; the other pedal assembly includes both right pedals. Control cables, connected to the pedals with turnbuckles, are routed aft along the sides of the fuselage. They pass through three sets of pulleys and are attached to the rudder horn outside the fuselage. The rudder cables are kept tight by springs attached to the forward side of the pedal assemblies. The airplane has a steerable tail wheel which is controlled by springs connecting the tail wheel steering arms to a special horn at the bottom of the rudder.

RUDDER CONTROL SYSTEM ADJUSTMENT

21. Rudder travel can be increased to meet the requirements of paragraph 5 by filing the rudder control horn. To decrease travel it is necessary to install tapered shims on control hinge fittings, under control horn.

22. The fore and aft position of the rudder pedals is varied by adjustment of the turnbuckles attaching each cable to the rudder pedals. Access to these turnbuckles is obtained through the snapped down flap in cabin side-wall trim panel beside each of the outer rudder pedals. (See figure 12.)

RUDDER TRIM BUNGEE SYSTEM

23. The model 108-2 airplanes are equipped with a rudder trim bungee control. (See figure 29.) This control system consists of a knob control in the cabin ceiling and a spring bungee mechanism located behind the cabin rear wall. The control and bungee mechanisms are connected by a cable. The bungee mechanism connects to the rudder system with two cables.

RUDDER TRIM BUNGEE CONTROL ADJUSTMENT

24. Correct rigging of the rudder trim control will affect the rigging of the rudder and elevator trim tab control systems. The following

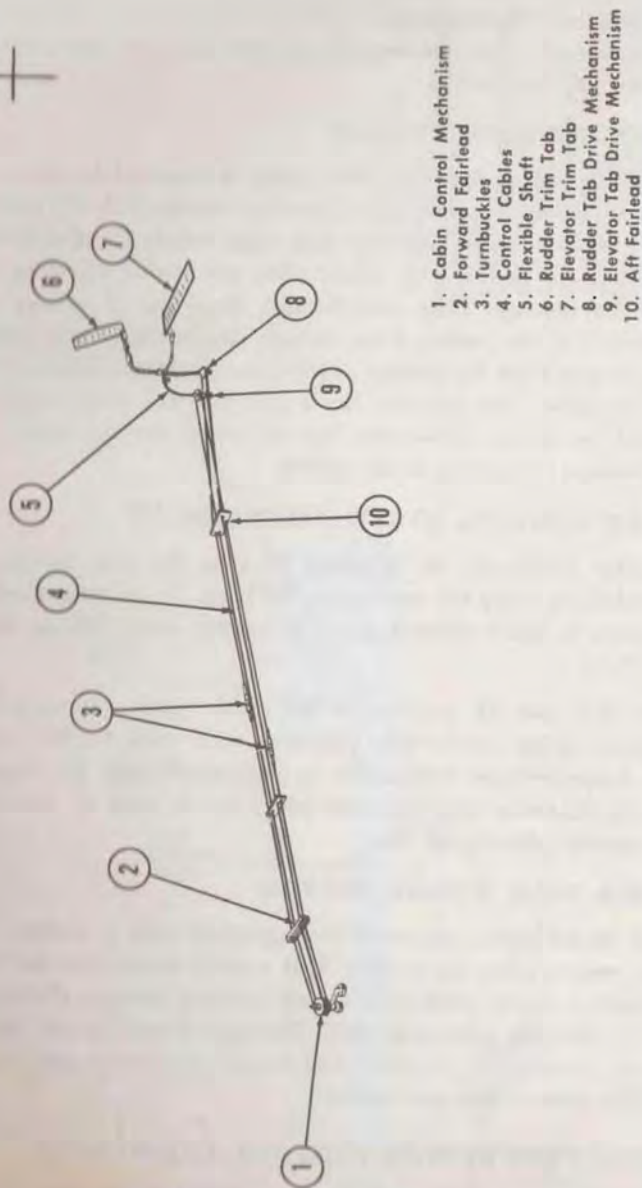

Figure 30—Trim Tab Control Systems

procedure for rigging the rudder bungee control system is recommended:

(a) Turn bungee pulley so as to move shaft of mechanism as far to the left side of airplane as possible.

(b) Adjust cable running between control knob and bungee so that splice fittings have 1.50 inches clearance with the bungee pulley.

(c) Turn bungee pulley five and one-quarter full turns to place mechanism in neutral position.

(d) Adjust cables connecting bungee with rudder system so that rudder is neutral. Tighten turnbuckles until bungee spring *STARTS* to extend and then turn back so that bungee arms are seated on shaft ends.

(e) Adjust turnbuckles in rudder pedal cables so that pedals are neutral with rudder trimmed as required for level flight cruising. These turnbuckles are accessible through a snapped sown flap in the cabin side-wall trim beside each of the outer rudder pedals.

(f) Tighten rudder bungee cable by sliding cabin control forward on its support tube. Cable should have about 5 pounds cable tension.

(g) Tighten elevator trim tab cable to a tension of between 10 and 20 pounds. Turnbuckle for this cable is accessible through the baggage compartment by unsnapping the upper canvas curtain.

RUDDER TRIM TAB CONTROL

25. The model 108-3 airplanes are equipped with a controllable rudder trim tab. The tab, located in the rudder trailing edge, is operated by a control knob in the cabin ceiling. A continuous cable connects the forward control mechanism to a pulley at the aft end of the fuselage. The ends of the cable are connected in the after portion of the fuselage. Refer to figure 30. The aft pulley drives a flexible shaft which in turn actuates a push-pull tube by means of a screw jack. The push-pull tube is attached to the rudder tab control horn. Adjustable stops which limit the travel of the tab are incorporated in the aft pulley assembly.

RUDDER TRIM TAB CONTROL ADJUSTMENT

26. To rig rudder trim tab proceed as follows:

(a) Center stop plate of drive mechanism in rear of fuselage.

(b) Turn clevis end of control screw in rudder until tab trailing edge is in line with rudder trailing edge.

(c) Turn drive mechanism until full right travel of tab is obtained, refer to paragraph 5.

(d) Set stop nuts controlling right tab travel against stop plate on drive mechanism.

(e) Repeat steps c and d for left tab travel.

(f) Check cabin control for freedom of motion through full tab travel. When control cannot be turned, be sure it is because of the control stops, and not that the turnbuckle is hitting a fairlead.

ELEVATOR TRIM TAB CONTROL SYSTEM

27. The elevator trim tab control is similar to that of the rudder, the same type of units and mechanisms being used. Refer to paragraphs 25 and 26, and to figure 30 for details and instruction regarding the adjustment of this equipment.



CHAPTER V

LANDING GEAR, BRAKES, AND WHEELS

GENERAL

1. The landing gear is of conventional type. The hydraulic brakes are actuated by toe-action pedals that are mounted on the rudder pedals. To operate either brake, apply force to the corresponding pedal. A push-pull type parking brake control is provided. To set the parking brake, apply force to both brake pedals and pull out the control knob. Hold control knob out until feet are taken off pedals. To release the parking brake, push in the control knob and apply force to the brake pedals; then release the pedals.

2. The main landing gear is equipped with spring-oil shock absorber strut. The steerable tail wheel assembly has a leaf spring to cushion shocks. The tail wheel tire is solid. The main wheel tires are size 7.00 x 6, 4 ply.

MAIN LANDING GEAR

3. (Refer to figure 31.) Each main landing gear consists of a tapered beam, a spring-oil shock absorber strut, a tire and tube, and a hydraulic disc-type brake assembly.

4. The landing gear beams are heat-treated chrome molybdenum steel tapered tubes. The axles are pressed into the lower end of the beams and are locked in place with bolts through the beams and axles. The beams hinge to the fuselage side with bronze bushings that rotate on steel pins. The upper end of the beams connect to spring-oil shock absorber struts that join the beams to the center of the fuselage.

5. Aluminum alloy fairings are installed to cover the landing gear beams and wheels. The wheel fairings are each attached to the landing gear with two screws on the outboard side and three screws on the inboard side. The beam fairings are attached to the lower end and to the center of the beams. The fuselage fillet fairings are attached to the fuselage with screws to permit removal of the landing gear beams.

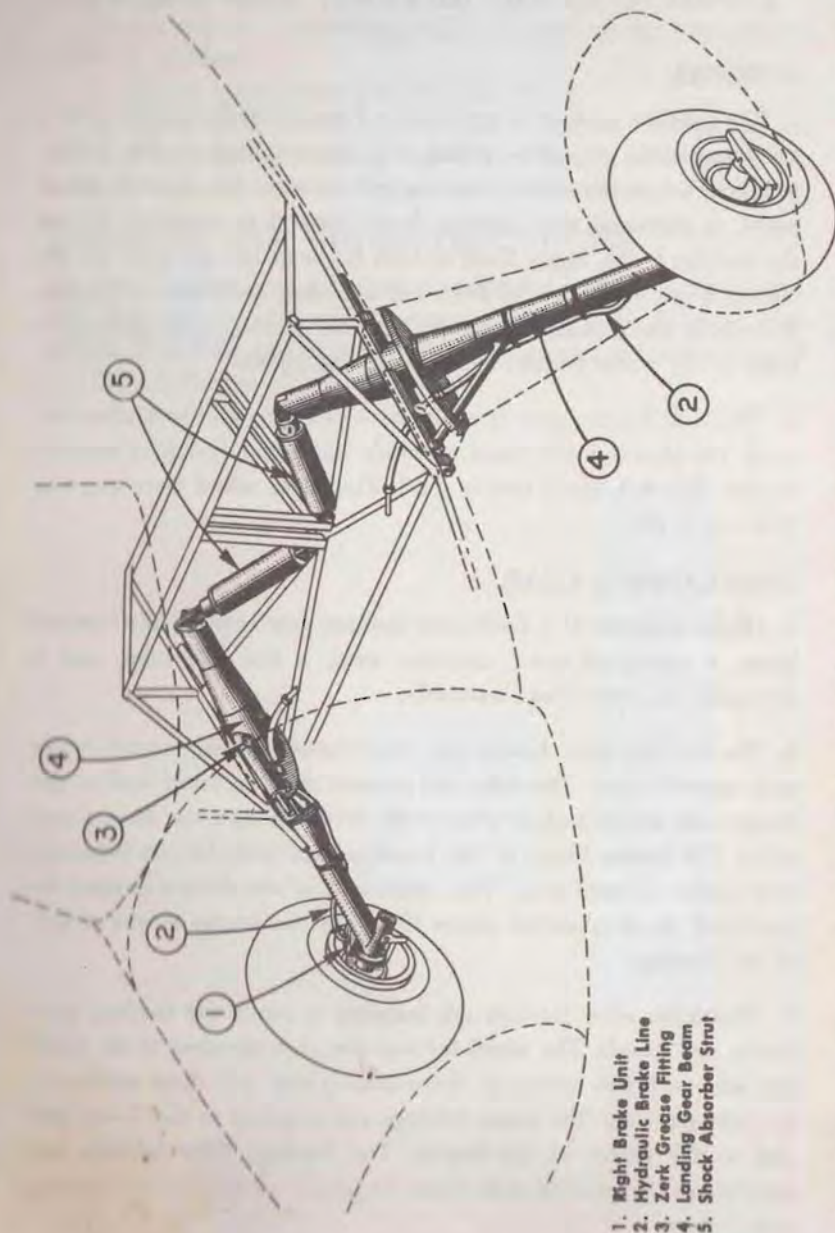

1. Right Brake Unit
2. Hydraulic Brake Line
3. Zerk Grease Fitting
4. Landing Gear Beam
5. Shock Absorber Strut

BEAM REMOVAL

6. The procedure for removing the landing gear beam is as follows:
 - (a) Hoist or jack the airplane until the wheel clears the ground. Refer to Chapter II.
 - (b) Unless the fuselage belly cover has been removed for jacking purposes, remove the fuselage tunnel cover just behind the firewall in the fuselage belly.
 - (c) Remove the landing gear fairings.
 - (d) Drain the brake system and disconnect the brake line at the flexible hose near the landing gear hinge.
 - (e) In the cabin, remove the front seats, the shock absorber cover, and the floor panels directly under the front seats.
 - (f) Remove cotter pin from forward end of the hinge pin. Place a drift punch in the hole at the rear of the hinge pin, and drive the pin out to the rear.
 - (g) Remove the beam by pulling it down and out of the fuselage.

BEAM MAINTENANCE

7. The beam is heat-treated to 180,000 to 190,000 psi tensile strength. Make welded repairs to the beam only when heat-treating facilities are available. The beam can be reheat-treated a maximum of five times before scaling will impair the thickness and strength of the beam.

BEAM INSTALLATION

8. Install landing gear beam as follows:
 - (a) Insert beam into fuselage and install hinge pin. Hinge pin is started from rear and driven forward. Be sure small cotter pin hole is forward and larger drift pin hole is aft when inserting the hinge pin. Shim hinge on either side of beam with washers to eliminate force and aft play.
 - (b) Install cotter pin through forward end of hinge pin to lock pin in place.
 - (c) Grease hinge pin with Specification AN-G-15 grease using grease gun applied to zerk fitting on beam.
 - (d) Bolt upper end of beam to shock absorber strut. Grease bolts and fittings with Specification AN-G-15 grease before installing bolt.
 - (e) Reassemble cabin.
 - (f) Connect the brake line at the flexible hose near the landing

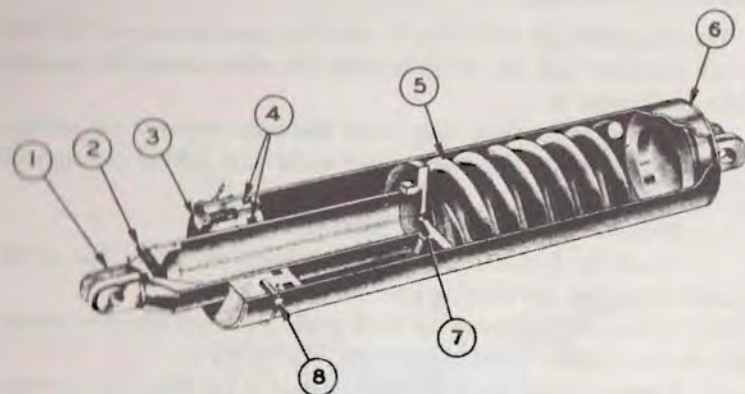

- | | |
|------------------|---------------------------|
| 1. Piston | 5. Spring |
| 2. Filler Plug | 6. Cylinder |
| 3. Bleeder Screw | 7. Orifice Hole in Piston |
| 4. Ring Seals | 8. Retaining Pin |

Figure 32—Shock Absorber Assembly

gear hinge. Fill the brake system (refer to paragraph 50 of this chapter).

(g) Install all fairings and covers.

SHOCK ABSORBER STRUTS.

9. Each main landing gear beam is attached to a spring-oil shock absorber strut. (Refer to figure 32.) The shock of landing is absorbed by the oil, as it is forced from one chamber to another through a small opening. The spring absorbs the small shocks of taxiing.

SHOCK ABSORBER REMOVAL AND DISASSEMBLY

10. The following is the procedure for the removal and disassembly of the shock absorber struts.

(a) Hoist or jack the airplane until the wheels are barely touching the ground.

(b) Remove the seats and the shock absorber cover in the cabin.

(c) Detach the shock absorber strut from the beam and from the fuselage.

(d) Disassemble shock absorber by removing the lock wire and pulling out the retaining pins. Pull piston from cylinder, forcing retainer off with piston.

SHOCK ABSORBER MAINTENANCE

11. Inspect the cylinder and the piston for roughness, scoring, and bending. Replace all worn or damaged parts.

12. Keep the strut full of petroleum base hydraulic fluid, Specification No. AN-VV-0-366b. After each 100-hour period of operation, remove the filler plug first and then remove the bleeder screw and add hydraulic fluid slowly through the filler plug in the piston until fluid flows out of the bleeder hole. Run a wire through the bleeder hole to ascertain that it is clear. Wait until fluid stops coming out of the bleeder hole and then install the bleeder screw. Always have the shock absorber strut installed in the airplane and have the airplane on the wheels when filling the strut with fluid.

13. If the shock absorber strut does not compress when the airplane is landing, remove and disassemble the strut, and clean the small hole in the bottom of the piston. When reassembling, fill cylinder with fluid and remove the bleeder screw before inserting piston.

14. If it is necessary to add fluid frequently, check the seals for deterioration. If the condition of the seals is doubtful, replace them. Polish out scores in piston if present.

SHOCK ABSORBER INSTALLATION

15. Install the strut with the cylinder bleeder screw and piston filler plug on top. Bolt base of cylinder to fuselage center fitting, and bolt head of piston to upper end of landing gear beam. Coat fittings and bolts with grease, Specification AN-G-15, before assembling.

MAIN LANDING GEAR WHEELS

16. (Refer to figure 33.) The wheels are either Goodyear type PD-140 with wheel assembly 511960 (with .312-inch brake disc) and brake assembly 511972, or Goodyear type PD-127-2 with wheel assembly 511413-M-1 (with .188-inch brake disc) and brake assembly 511640. The castings are magnesium alloy.

17. The wheels are statically balanced and are marked at the factory to indicate how the two halves should be aligned in relation to each other to insure proper balance when the wheel is assembled. The balance mark is the letter "B" stamped on one of the bolt bosses on each half wheel. The same bolt must go through the bosses marked "B".

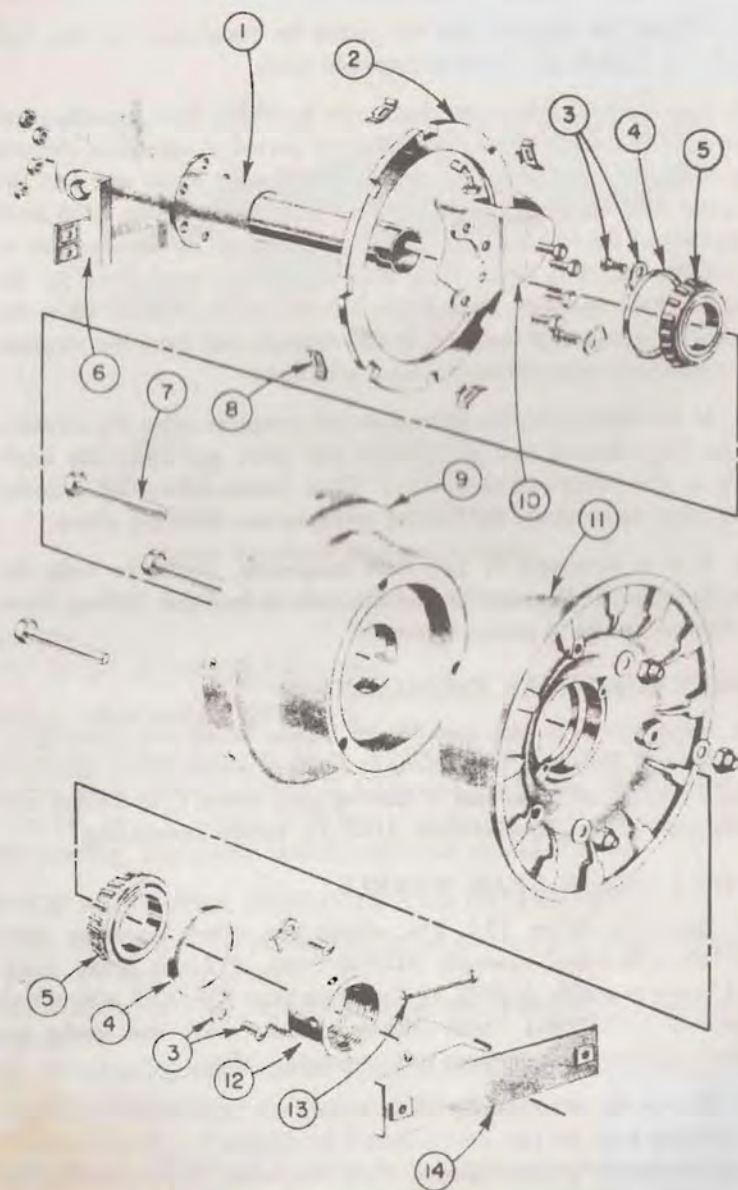

Figure 33—Main Wheel Assembly

18. Two tapered roller bearings are used in the wheel. The bearings are seated in hardened steel bearing cups at the inboard and the outboard ends of the wheel castings.

MAIN LANDING GEAR WHEEL REMOVAL

19. Remove the main landing gear wheels as follows:

- (a) Insert the tubular jacking tool, part No. 108-5901000, into the axle, and jack the wheel clear of the ground. Refer to Chapter II.
- (b) Remove the wheel fairing and the outer wheel fairing support.
- (c) Turn off the retainer nut.
- (d) To free the brake disc on the inside of the wheel, remove the four spring clips. To remove a spring clip, insert a flat piece of metal between the spring clip and the wheel, and force the back edge of the spring clip over the boss in the wheel, then pull the clip out. (Refer to paragraph 20, following.)
- (e) Pull wheel off axle.

TOOL FOR REMOVAL OF BRAKE DISC SPRING CLIPS

20. The removal of the brake disc spring clips, as described in paragraph 19d, will be facilitated if a tool similar to that illustrated in figure 34 is available. This tool can be made from .040-inch spring steel.

MAIN LANDING GEAR WHEEL MAINTENANCE

21. The wheels are given a protective coating to prevent corrosion. If the protective coating is chipped, worn through, or removed in any manner, recoat the part immediately to prevent corrosion. Before recoating, remove all corrosion with a fine file or a scraper, and

Figure 33—Main Wheel Assembly

1. Axle
2. Brake Disc
3. Bearing Retainer Screws
4. Bearing Retainer
5. Bearings
6. Inner Wheel Pant Support
7. Wheel Assembly Bolts
8. Spring Clips
9. Inner Wheel Half
10. Brake Unit
11. Outer Wheel Half
12. Retainer Nut
13. Safety Lock Pin
14. Outer Wheel Pant Support



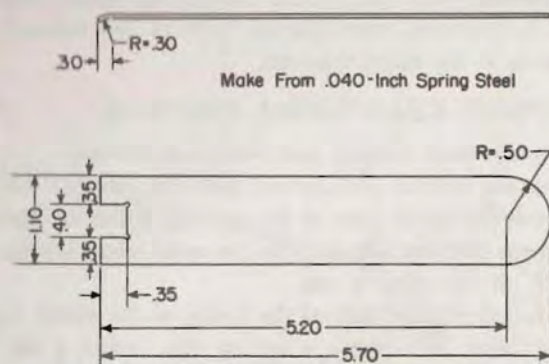

Figure 34—Tool for Removing Disc Spring Clips

polish with fine emery cloth. The entire wheel, except for friction and bearing surfaces, must have the protective coating.

22. Remove or round all nicks so as to eliminate any sharp corners. A radius of .040-inch or larger is desired at all corners.

23. If it is necessary to refinish the wheel completely, first remove the old finish with paint remover. It is essential that the surfaces be cleaned thoroughly.

24. After the part is cleaned and repaired, treat the wheel with chrome pickle. The chrome pickle is composed of:

Sodium dichromate	1.5 pounds
Concentrated nitric acid (specific gravity 1.42)	1.5 pints
Water	6.5 pints

Apply the chrome pickle to the affected spot and allow it to dry for two or three minutes. Then wash the part thoroughly with clean cold water.

WARNING

Do not permit the chrome pickle to come in contact with the skin, because serious acid burns will result.

25. Paint all exposed parts with two spray coats of zinc chromate primer, Specification No. AN-TT-P-656. Allow the primer to dry

and then apply two coats of aluminum lacquer, Specification No. AN-L-29.

26. If it is impossible to refinish the wheel *completely*, bad spots can be touched up with aluminum lacquer. Use one or two coats, depending upon the condition of the surface.

CAUTION

If wheels are corroded on the inside, refinish or replace the wheels before using the airplane.

MAIN WHEEL BEARING MAINTENANCE

27. After each 100-hour period of operation, remove and disassemble the wheels, and remove the bearings. Wash the bearings in dry cleaning solvent, Federal Specification No. P-S-661. Repack the bearings with grease, Specification No. AN-G-15. Do not use excessive grease.

CAUTION

Do not force a bearing in or out of a wheel by hammering or pressing.

28. When it is necessary to remove the bearing cups from a wheel, heat the wheel before attempting to remove the bearing cups. A differential temperature between the wheel and the bearing cup of approximately 100° F. is necessary.

29. Replace bearing closure rings that are bent or distorted.

30. If felt seals are installed, wash the seals with dry cleaning solvent. If the seals have become worn and are allowing lubricant to escape, replace the seals. Before installation, lubricate either new or old seals with light machine oil, Federal Specification No. VV-O-581, grade 10.

MAIN LANDING GEAR WHEEL INSTALLATION

31. Install the main landing gear wheels as follows:

(a) Before installing a wheel be sure that it is correctly assembled so that it is properly balanced. Each wheel has balance marks stamped "B" on two of the bolt bosses. Assemble the wheel so that the two marked bosses are opposite each other, with the same bolt going through them.

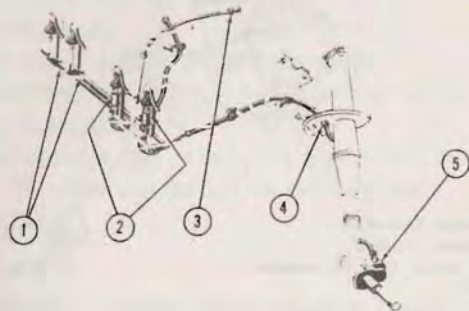

- 1. Grease Fittings
- 2. Brake Master Cylinders
- 3. Parking Brake Control
- 4. Hydraulic Brake Line Connection
- 5. Brake Unit

Figure 36—Brake System (Model 108-3)

38. The annular disc floats on the drive wheel keys. The floating action compensates for the fact that when hydraulic pressure is applied, only the outboard brake lining moves toward the disc, while the inboard lining remains stationary. As the outboard lining presses it, the floating disc moves away until it contacts the inboard lining also. The disc then receives equal clamping on both sides as hydraulic pressure is increased.

39. The brake assembly is either Goodyear 511972 or 511640. The assemblies are *not* interchangeable.

40. The brake assembly is self adjusting. As the brake linings wear, additional fluid will be required to eliminate excessive brake pedal travel.

- 1. Locknut
- 2. Parking Brake Attachment
- 3. Piston
- 4. Spring
- 5. Filler Plug
- 6. Pressure Release Pin
- 7. Reservoir
- 8. Pressure Outlet

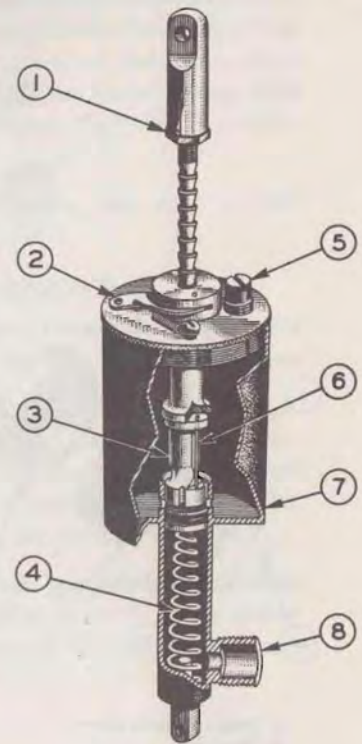
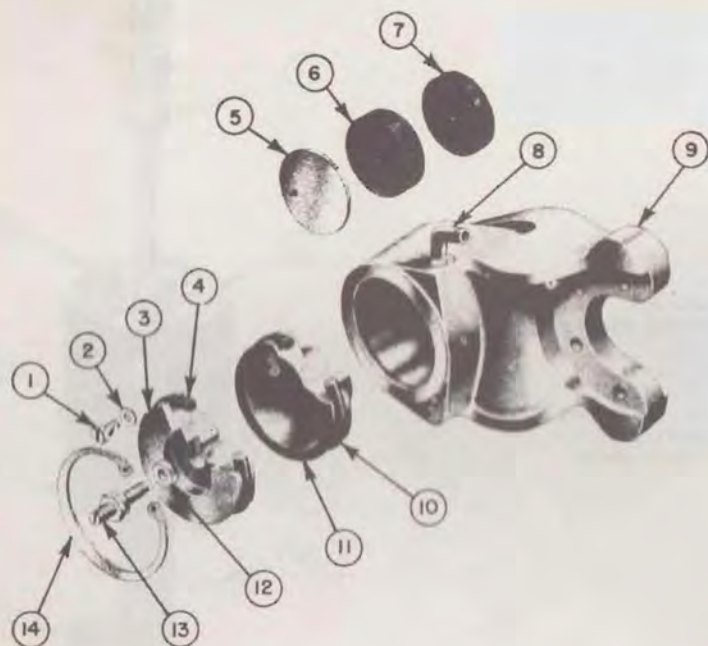

Figure 37—Brake Master Cylinder Assembly

BRAKE MASTER CYLINDERS

41. (Refer to figure 37.) One master cylinder, with parking brake device, is mounted forward of each of the pilot's rudder pedals. The cylinder contains a fluid reservoir which is filled through a hole in the top of the cylinder. When the brake pedal feels spongy and unresponsive, probably it is due to air in the lines. Remove the air by bleeding the brake system. If, after air has been bled from the system, the brake is unresponsive and the parking brake pressure does not hold, remove and disassemble the cylinder and replace the ring seal (AN 3227-2).

42. To change the position of the brake pedal, turn the upper fitting on the piston to increase or to decrease the piston length.



- | | |
|------------------------|-----------------------------------|
| 1. Brake Bleeder Screw | Hydraulic Line Inlet |
| 2. Washer | 9. Brake Housing |
| 3. Brake Cylinder Head | 10. Packing |
| 4. Packing | 11. Piston |
| 5. Pressure Plate | 12. Washer |
| 6. Piston Lining Block | 13. Brake Adjusting Screw |
| 7. Fixed Lining Block | 14. Brake Cylinder Head Lock Ring |

Figure 38—Brake Assembly

WHEEL BRAKE REPLACEMENTS

43. Replace the fixed lining block when it is $\frac{3}{16}$ inch or less in thickness.
44. Replace the piston lining block when it is $\frac{3}{8}$ inch or less in thickness. The worn piston lining block can be used as a replacement for the fixed lining block.
45. To install new lining blocks, remove the wheel and the brake disc. Remove the old lining blocks. Insert the new piston lining block first. Force the piston lining block into the brake assembly.

On some brakes it may be necessary to back out the adjusting screw (see figure 38). Then install the fixed lining block. Force the lining block apart far enough to allow the insertion of the brake disc; install the brake disc. Install the wheel. Fill the brake system with petroleum base hydraulic fluid, Specification No. AN-VV-0-366b. Refer to paragraph 50.

46. Replace piston seals that are damaged in any way or that are shrunk.

WHEEL BRAKE PERIODIC MAINTENANCE

47. After each 30-hour period of operation, inspect the brake units visually for any signs of seal leakage. Replace the seals if there is leakage.
48. After each 100-hour period of operation, make a general inspection of the brakes without disassembling the brake unit. Inspect for corroded or broken parts. Inspect the condition of nuts, bolts, and safety wire. Remove grease and oil with cleaning solvent.
49. After each 400-hour period of operation, completely disassemble the brake and inspect all parts. Thoroughly clean the brake piston seals and all other brake parts with cleaning solvent. Replace any unserviceable parts.

FILLING THE BRAKE SYSTEM

50. Refill the brake system as follows:

- Remove filler plug in master cylinder.
- Remove brake bleeder screw on the wheel brake unit and attach line from brake fluid pressure can. Fill system with petroleum base hydraulic fluid, Specification No. AN-VV-0-366b. If pressure can is not available, an open can with line attached may be used provided can is held higher than brake master cylinder. Add fluid until reservoir of master cylinder is full.
- Reinstall bleeder screw.
- Replace filler plug in master cylinder.
- Check brake to determine that operation is satisfactory.

BLEEDING THE BRAKES

51. An excessive amount of air in the brake system will result in ineffective brake action. This requires bleeding of the brake system as follows:

- (a) Check to determine that the entire brake system is connected.
- (b) Remove the bleeder screw from the brake and insert in its place a standard bleeder hose. Place the free end of the hose in a clean glass receptacle.
- (c) Remove the filler plug from the master cylinder.
- (d) Fill the master cylinder with clean petroleum base hydraulic fluid, Specification No. AN-VV-O-366b.

NOTE

During the bleeding process, keep the master cylinder filled with hydraulic fluid.

- (e) Actuate the brake pedal rapidly to force fluid through the bleeder hose into the receptacle. Pinch the bleeder hose (to close it) during the return of the brake pedal to the *off* position.
- (f) Release finger pressure on the bleeder hose and push the brake pedal *on* rapidly again. While the fluid is flowing, restrict the bleeder hose, and allow the brake pedal to return slowly to the *off* position.
- (g) Repeat this operation until no more air bubbles appear from the bleeder hose. The system then is properly bled.
- (h) Replace the bleeder screw and washer.
- (i) Check to ascertain that the master cylinder is filled with fluid.
- (j) Replace the filler plug in the master cylinder.
- (k) Check the brake to determine that operation is satisfactory.

CAUTION

Extreme care should be taken to see that the fluid container and all lines and fittings are absolutely clean. Any dirt or other particles in the system may stick in the master cylinder compensating port and result in a locked or dragging brake. Such particles might work under the seals on the master cylinder piston or under the brake piston and cause leaks.

DRAINING THE BRAKE SYSTEM

52. The brake system is drained as follows:
- (a) Remove the brake bleeder screw.
 - (b) Remove the filler plug in the master cylinder.
 - (c) Pump the brake pedal until fluid no longer drains out of the brake bleeder opening.

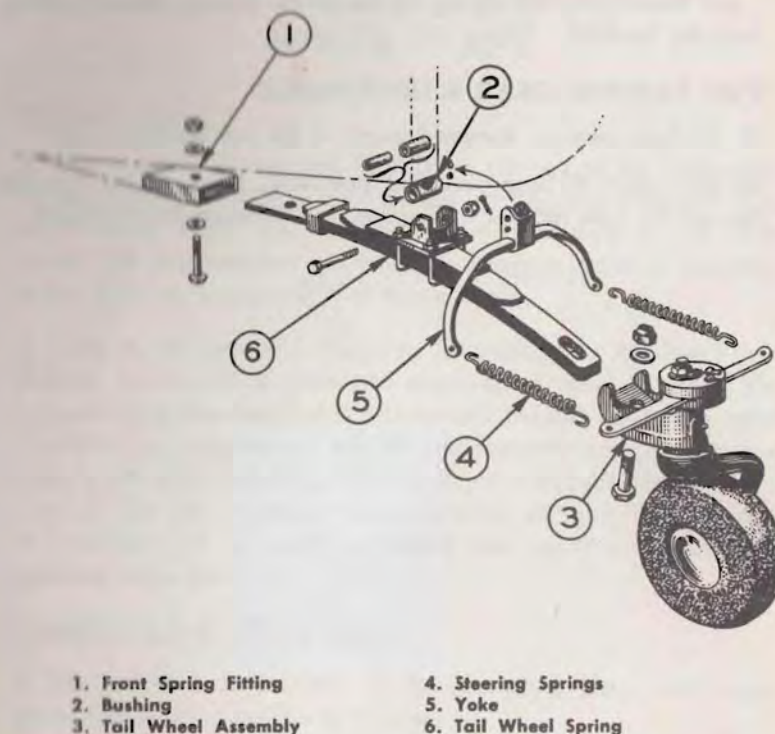

Figure 39—Tail Landing Gear Assembly

TAIL LANDING GEAR

53. (Refer to figure 39). The tail wheel unit is a full-swiveling, solid tired unit. The wheel is mounted on a leaf spring that is attached to the fuselage. The steering arms are connected to a rudder yoke with two springs. The wheel is steered through a limited arc by movement of the rudder pedals. Beyond this arc a release disengages the wheel and provides full swiveling action of the unit.

TAIL LANDING GEAR REMOVAL

54. The following is the procedure for removing the tail landing gear.
- (a) Shore up the rear end of the airplane.
 - (b) Disconnect the steering springs and unbolt the unit from the leaf spring.

(c) Remove the leaf spring retaining bolt. Remove the leaf spring from the fuselage.

TAIL LANDING GEAR MAINTENANCE

55. Replace worn or damaged parts of the tail landing gear.
56. After each 25-hour period of operating, lubricate the knuckle through the Zerk fittings, with grease, Specification No. AN-G-15.

CHAPTER VI

POWER PLANT

PROPELLER

1. The propeller is mounted directly on the end of the crankshaft. A flange type mounting is used having a 5.250 inch diameter circle of mounting holes. The 6A4-150-B31 engines used on the early model 108 airplanes has a 5.000 inch diameter circle of mounting holes. Refer to paragraph 7 of this chapter.
2. Refer to the Approved Operating Limitations, or Airplane Flight Manual, for the list of propellers approved on these airplanes. The standard propeller installed is a Sensenich 76JR53 fixed-pitch wood propeller. Airplanes having a 5.000 inch diameter circle of mounting holes in the crankshaft flange were equipped with Sensenich propeller 76JA53. The 165 horsepower engine used in the model 108-2 and -3 is provided with an outlet permitting the use of a hydraulically operated propeller.

PROPELLER INSTALLATION

3. The propeller is installed on the crankshaft flange with eight studs. Install the propeller as follows:
 - (a) Install propeller with the large spinner plate between the propeller and the engine.
 - (b) When installing the fixed-pitch wood propeller, install the smaller spinner plate on the face of the propeller. The large spinner plate should be installed with all propellers. The forward plate is only used when the propeller spinner is used.
 - (c) Tighten each of the eight hub bolts finger tight. Use a torque wrench for final tightening and tighten in sequence so that all bolts are pulled down evenly. Tighten bolts to a torque of 125 to 175 inch pounds.

PROPELLER TRACKING

4. After the propeller is installed, and before installing the spinner, track the propeller as follows:
 - (a) Place a box or other fixed object at the lower tip while the propeller is in a vertical position.

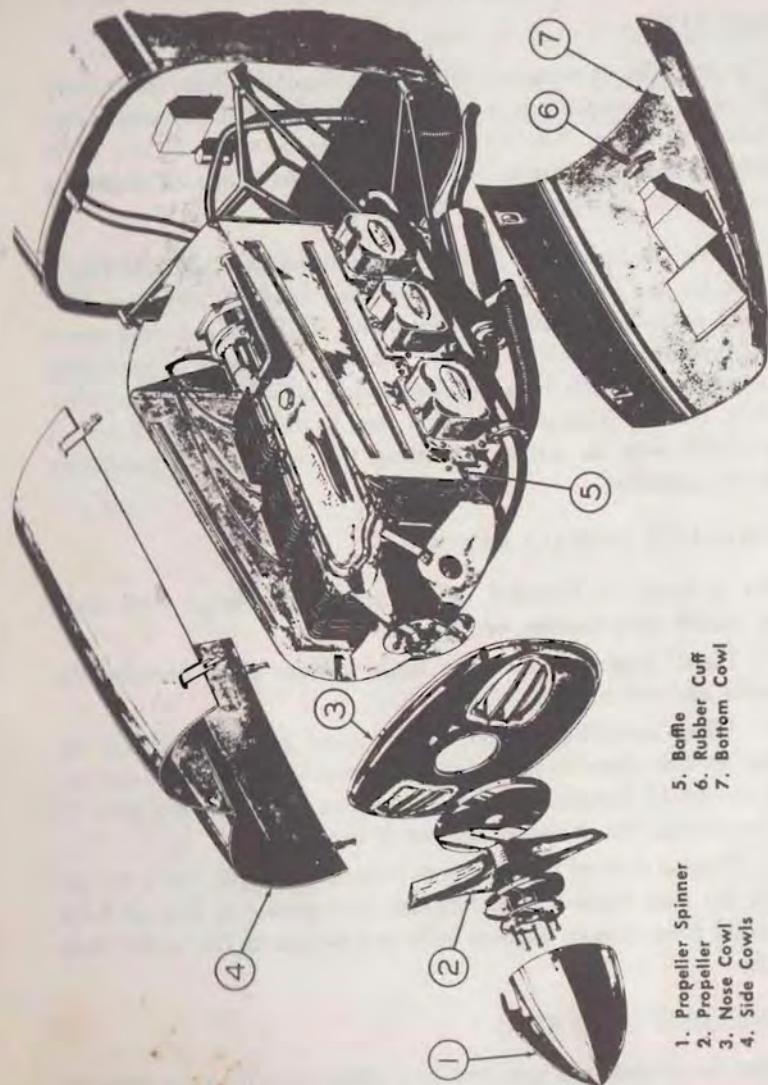

Figure 40—Propeller and Cowling

- 1. Propeller Spinner
- 2. Propeller
- 3. Nose Cowl
- 4. Side Cowls
- 5. Baffle
- 6. Rubber Cuff
- 7. Bottom Cowl

(b) Mark the line of the tip plane on the box.
 (c) Rotate the propeller through 180 degrees and compare the location of the second tip with respect to the first. The two tips must pass within $\frac{1}{16}$ inch of the same line. If the tips are more than $\frac{1}{16}$ inch apart, loosen and tighten hub bolts until the tracking is satisfactory.

ENGINE COWL

5. The engine cowl is made in four pieces: the nose cowl, the bottom cowl, and the two side cowls. Refer to figure 40. The bottom cowl is attached to the fuselage at the rear, and to the nose cowl in front. The side cowls are fastened together with a continuous hinge along the top. The front end of the hinge is attached to the nose cowl and the rear end is attached to a bracket at the firewall. Each side cowl is locked to the bottom cowl with two lock straps that fasten with trunk type fasteners. The hinged side cowls afford ample access to the engine. Internal baffles are mounted on the engine.

ENGINE COWL REMOVAL

6. Remove the engine cowling as follows:
 (a) To remove the side cowls, unfasten the lock straps, unfasten the hinge from the nose cowl and from the bracket at the firewall, and lift off both side cowls together.
 (b) To remove the bottom cowl, unfasten (or remove) the side cowls, disconnect the carburetor hot air and cold air intakes, and remove the screws that attach the bottom cowl to the fuselage and to the nose cowl.
 (c) To remove the nose cowl it is necessary to remove the propeller. After removing the propeller, unfasten the side cowl from the top and the bottom cowl from the bottom edge. If both the bottom cowl and the nose cowl is to be removed, they may be taken off together.

ENGINE

7. All models are equipped with Franklin six-cylinder, direct-drive, clockwise-rotation (from pilot's position), horizontally opposed engines. The engine is mounted on a tubular steel mount which is bolted to the front of the fuselage structure. Refer to figures 41 through 45. The models 108 and 108-1 are equipped with either the 6A4-150-B31 or the 6A4-150-B3 engine. The major difference

between these two engines is the diameter of the ring of propeller mounting holes in the crankshaft flange. The -B31 engine has 5.000-inch diameter and the -B3 has a 5.250-inch diameter. The models 108-2 and 108-3 are equipped with 6A4-165-B3 engines.

8. The Franklin engine incorporates many features to aid in extending the time between overhauls and to minimize the extent of major repairs. The cylinders are of one-piece construction and are made of heat-treated copper-aluminum alloy. The cylinders are fitted with replaceable nickle-iron alloy liners. Heli-Coil spark plug bushings are installed to preclude the possibility of spark plugs sticking in place. The Heli-Coil bushings are readily replaceable in case the threads become damaged. Hydraulic valve lifters are installed to insure smooth, trouble-free, quiet valve operation. The hydraulic valve lifters require no maintenance.

ENGINE SPECIFICATION

	6A4-150-B3	6A4-165-B3
Rated Horsepower	150	165
Rated Speed (rpm)	2600	2800
Fuel (minimum octane)	80	80
Compression Ratio	7.0:1	7.0:1
Displacement (cu. in.)	335	335
Bore and Stroke (inches)	4.5x3.5	4.5x3.5
Carburetor (Single)	Marvel-Schebler MA-3SPA	Marvel-Schebler MA-4-5
Magnetos (Dual)	*Eisemann LA-6	*Scintilla 55RN-21
Spark Plugs (12)	*Champion J-10	*Auto-Lite AH-4
Ignition Timing	28° b.t.c.	32° b.t.c.
Firing Order	1-4-5-2-3-6	1-4-5-2-3-6
Propeller	†Sensenich 76JA53 or 76JR53	†76JR53
Starter	Delco-Remy 1109651	Delco-Remy 1109651
Generator	Delco-Remy 1101877	Delco-Remy 1101877
Voltage Regulator	Delco-Remy 1118263	Delco-Remy 1118263
Air Filter	Air Maze C-13197	Air Maze C-13197
Oil: Above 40°F	SAE No. 40	SAE No. 40
Below 40°F	SAE No. 20	SAE No. 20
Oil Capacity	8 Qt.	9 Qt.
Minimum Oil for Operation	4 Qt.	5 Qt.
Oil Temperature: Maximum	230°F	230°F
Minimum	60°F	60°F
Oil Pressure: Maximum	55 p.s.i.	55 p.s.i.
Minimum	35 p.s.i.	35 p.s.i.
Weight (Including Oil Cooler, Starter, Generator, Carburetor and Magnetos)	316.8	323.5

*Equipment interchangeable between engines.

†Standard Equipment. See Airplane Flight Manual for alternate propellers. 6A4-165-B3 engines provided with necessary outlets for hydraulically operated propeller.

ENGINE OPERATION

9. Operation of the engine is fully explained in the OWNER'S OPERATING MANUAL. Refer to that book for starting, ground testing, and stopping the engine. The following are the most likely causes for improper functioning of the engine.

INADEQUATE FUEL SUPPLY

10. Check the fuel supply in the tanks. Check to be sure that the fuel selector valve is *on*, and that fuel is reaching the carburetor. Disconnect the fuel line at the carburetor inlet port. Remove the fuel strainer from the carburetor and examine for dirt or obstructions. Replace the fuel strainer in the carburetor and reconnect the fuel line. Drain fuel from the tanks and from the fuel strainer on the fire wall to remove any water.

UNDERPRIMING

11. Underpriming can be due to an insufficient number of priming strokes, to loose primer pump packing and/or primer lines, or to lack of fuel at the primer pump. Disconnect one of the primer lines at the engine and operate the pump. If fuel does not flow from the line, investigate further and correct the cause.

OVERPRIMING

12. In warm weather, or with a hot engine, overpriming often prevents engine starting. If overpriming is suspected, open the throttle fully, place the mixture control in *idle cut-off*, and turn the engine over several complete revolutions. Then repeat the starting procedure, using fewer priming strokes.

INCORRECT MIXTURE

13. Unless the mixture control is in *full rich* position (knob full in) and the throttle knob is approximately 1/4 inch open, difficulty in starting may arise.

IGNITION MALFUNCTIONING

14. The most common ignition difficulties are the following:
- Moisture, oil, or dirt on the spark plug lead connectors, and broken or cracked connectors.
 - Broken wires and burned or chafed insulation.
 - Improperly gapped spark plug electrodes or spark plugs that

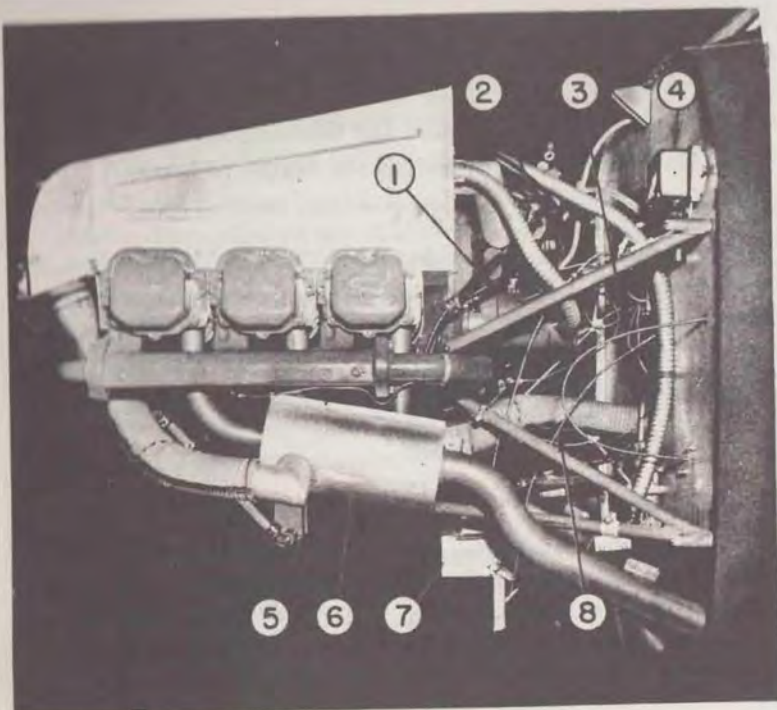

- | | |
|--------------------------|--------------------------------|
| 1. Generator | 5. Oil Cooler |
| 2. Left Magneto | 6. Cabin Air Heater Muff |
| 3. Parking Brake Control | 7. Carburetor Air Mixing Box |
| 4. Voltage Regulator | 8. Carburetor Air Heat Control |

Figure 41—Engine Left Side (Model 108)

are fouled with oil, carbon, or lead deposits. (The proper electrode gap is .014 to .018 inch.)

(d) Magneto breaker points that are dirty, pitted, or improperly timed with reference to the timing mark on the engine.

(e) Low electrical output of magnetos. Disconnect a spark plug lead and hold it from $\frac{1}{4}$ to $\frac{3}{8}$ inch from a grounded surface while the engine is being turned over. At normal starting speed, if the spark which arcs this gap is weak, improper functioning of the magnetos should be suspected.

(f) Defective ignition switch.

(g) Improper magneto timing, either internally or with respect to the engine timing mark.

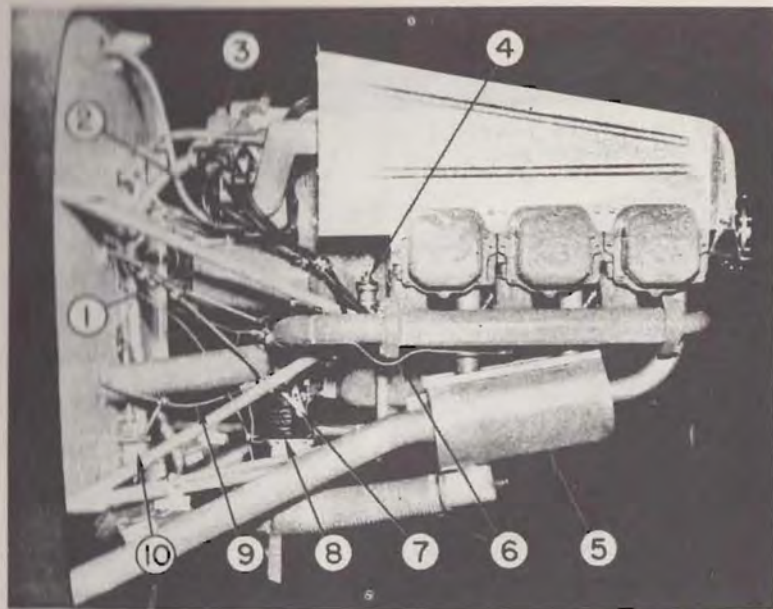

- | | |
|--------------------------|---------------------|
| 1. Generator | 6. Primer Line |
| 2. Right Magneto | 7. Throttle Control |
| 3. Starter | 8. Carburetor |
| 4. Engine Shock Mount | 9. Mixture Control |
| 5. Carburetor Air Heater | 10. Fuel Strainer |

Figure 42—Engine Right Side (Model 108)

IMPROPER CARBURETION

15. The most common carburetor difficulties are the following:

(a) Dirt in the carburetor. Remove the strainer that is built into the carburetor at the fuel inlet and inspect to insure free passage of fuel and for the absence of an excessive amount of foreign material.

(b) Water in the fuel. Drain fuel from the carburetor. If water is present, drain fuel from both tanks and from the fuel strainer on the fire wall until all water is removed.

(c) Carburetor loose or leaking at the mounting flange. Rectify external leaks where possible. If the difficulty is internal, remove the carburetor and have it repaired or replaced.

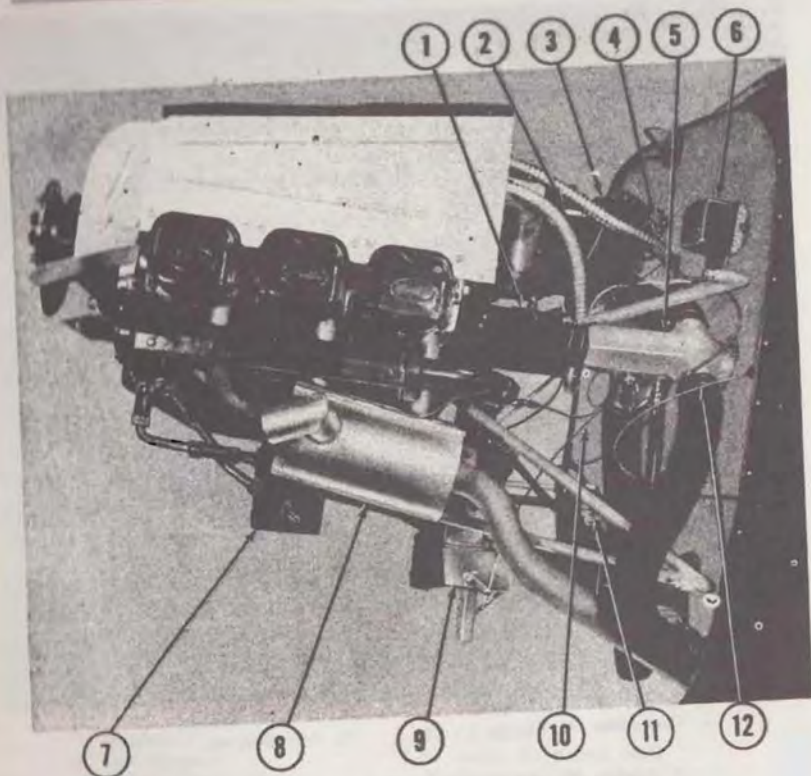

- | | |
|--------------------------------|---------------------------------|
| 1. Generator | 7. Oil Cooler |
| 2. Starter | 8. Cabin Air Heater Muff |
| 3. Battery (Model 108-3) | 9. Carburetor Air Mixing Box |
| 4. Battery Relay (Model 108-3) | 10. Carburetor Heat Control |
| 5. Cabin Heater Valve | 11. Oil Drain Models 108-2, -3) |
| 6. Voltage Regulator | 12. Parking Brake Control |

Figure 43—Engine Left Side (Models 108-1, -2, -3)

IMPROPER VALVE ACTION

16. Among valve troubles are the following:

- (a) Sticky valves.
- (b) Broken valve springs.
- (c) Bent or worn push rods.
- (d) Incorrect valve clearance adjustments.
- (e) Improper functioning of the hydraulic valve lifter mechanism.

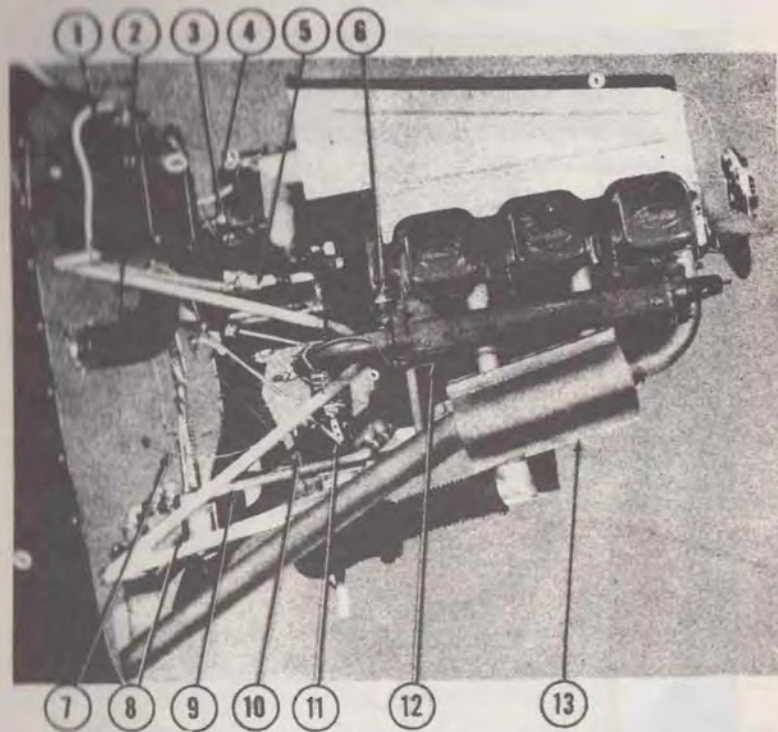

- | | |
|--------------------------|---------------------------------|
| 1. Battery (Model 108-3) | 7. Mixture Control |
| 2. Cabin Heater Duct | 8. Fuel Strainer |
| 3. Right Magneto | 9. Oil Drain (Models 108-2, -3) |
| 4. Starter | 10. Carburetor |
| 5. Generator | 11. Throttle Control |
| 6. Engine Shock Mount | 12. Engine Primer Line |
| | 13. Carburetor Air Heater Muff |

Figure 44—Engine Right Side (Models 108-1, -2, -3)

ENGINE OPERATING WITH LOW OIL PRESSURE

17. If oil pressure is low during engine operation, investigate the following conditions to determine the cause. (Engine oil pressure should be between 35 and 55 p.s.i.)

- (a) Lack of oil in the engine. A minimum of four quarts in the 150 horsepower engines and five quarts in the 165 horsepower engines is required for operation.

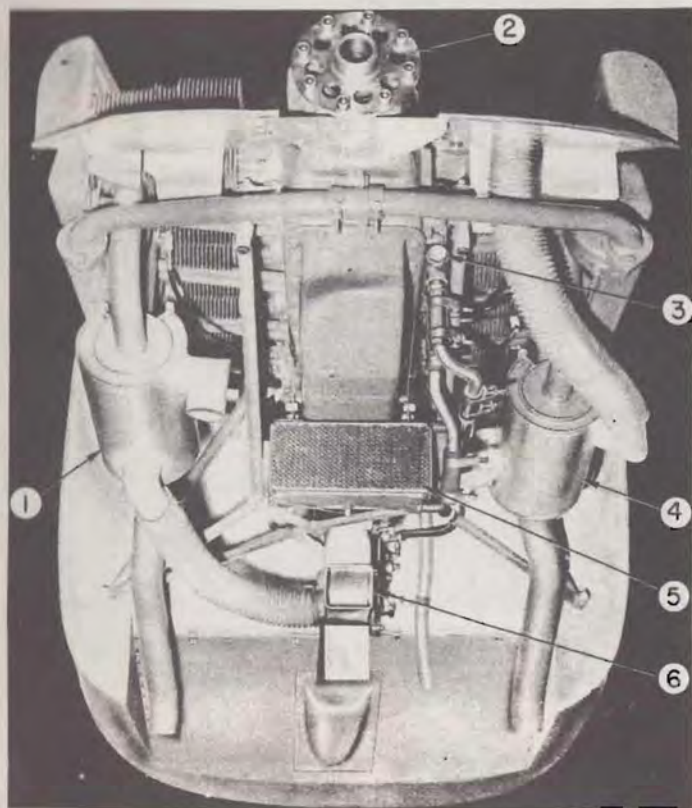

- | | |
|--|------------------------------|
| 1. Carburetor Air Heater Muff | 4. Cabin Air Heater Muff |
| 2. Propeller Mounting Flange | 5. Oil Cooler |
| 3. Oil Pressure Relief Adjusting Valve | 6. Carburetor Air Mixing Box |

Figure 45—Engine Front (Model 108)

- (b) Air or congealed oil in the pressure gauge line.
- (c) Broken or defective pressure gauge.
- (d) Improper seating of the oil pressure relief adjusting valve.
- (e) Inadequate spring force in the oil pressure relief adjusting valve.

- (f) Improper functioning of the oil pump.
- (g) Excessive oil inlet temperature.
- (h) Use of oil that is improper or unsatisfactory to engine requirements.

18. If low oil pressure persists, despite correction or non-existence of the conditions listed above, partial or complete disassembly may be necessary to detect and to remedy the condition. Bushings, bearings, oil seal rings, and shafts should be inspected for excessive wear. Oil pipes and connections within the engine should be checked for tightness and fit.

If metal particles of appreciable size or quantity are found in the oil system upon removal of the oil drain plug, determine the cause before further engine operation. Metal particles are usually present in oil drained from a new engine, but this does not indicate wear of engine parts. If metal particles are found in oil drained from an engine that has been in service for some time, however, wear of parts should be suspected.

LOW POWER

19. If the engine fails to develop normal power, the most likely cause is improper functioning of the ignition system. Make the following tests to determine the cause:

(a) Test the ignition by running momentarily on each magneto at 2000 r.p.m. In switching from both magnetos to one, the normal drop-off should not exceed 200 r.p.m. Avoid engine operation on one magneto for periods of over 15 seconds duration to prevent engine damage due to detonation.

20. If the drop in speed on either magneto is in excess of 200 r.p.m. under the speed with both magnetos operating, investigate for the following conditions:

- (a) Defective ignition wire terminal sleeves.
- (b) Defective or fouled spark plugs.
- (c) Broken or damaged ignition wires.
- (d) Incorrect timing and operation of the magnetos.
- (e) Defective condenser or broken breaker point spring in a magneto.

21. If it is determined that ignition malfunctioning is not the cause of low power, investigate the following miscellaneous conditions to

determine the cause:

- (a) Failure of throttle valve to open fully.
- (b) Restrictions in air intake system.
- (c) Defective valve in carburetor air mixing box. This condition can cause an excessive rise in carburetor air temperature.
- (d) Inadequate fuel supply at carburetor.
- (e) Air leakage into the induction system.
- (f) Poor compression due to improperly seated valves, worn piston rings, or loose spark plugs.
- (g) Improper operation of valve mechanisms.
- (h) Incorrect grade of fuel.
- (i) Ice formation in the induction system.
- (j) Improper setting or functioning of the carburetor.

ROUGH RUNNING

22. The following conditions are to be investigated if engine operation is "rough," causing excessive vibration.

23. Check the propeller for the following conditions:

- (a) Looseness of propeller bolts.
- (b) Unbalanced or improper tracking of the propeller.
- (c) Damage to the propeller.

24. Check the ignition system for the following conditions:

- (a) Defective spark plugs.
- (b) Loose, damaged, or broken ignition wires or connections.
- (c) Improper timing and operation of the magnetos.
- (d) Moisture, oil, or dirt on the spark plug connector sleeves.
- (e) Burned or damaged magneto breaker assemblies, coils, or condensers.

25. Check the fuel and induction systems for the following conditions:

- (a) Dirt or foreign matter in the fuel passages or strainers.
- (b) Air leaks in the induction system. Make certain that all intake pipe packings or gaskets are tight and that the induction system has not been damaged during installation. Check the ignition system to see that all spark plugs are installed.
- (c) Check the primer pump to ascertain if it is closed securely.

26. Check the valve mechanism for insufficient or excessive valve clearance.

27. Check the carburetor for the following conditions:

- (a) Poor mixture distribution due to inadequate carburetor heat.
- (b) Improper setting and functioning of the carburetor.
- (c) Carburetor loose or leaking at the mounting flange.

28. Check the engine mount for the following conditions:

- (a) Looseness of the retaining bolts, either at the engine or at the firewall. (Refer to Paragraph 32a of this chapter.)
- (b) Cracked or broken structural members of the engine mount.

HIGH OIL TEMPERATURE

29. When excessively high oil temperatures are present, check the following conditions to determine the cause:

- (a) Defective oil pressure relief adjusting valve.
- (b) Restrictions in the oil cooler system.
- (c) Clogged oil cooler.
- (d) Cowling or other objects that interfere with proper air flow over the engine.
- (e) Insufficient air flow around the oil pan due to alterations or changes in the cowling design.
- (f) Blow-by, resulting from burned or scored pistons and weak piston rings.
- (g) Partial or complete failure of a bushing or a bearing. Investigation for metal particles will usually indicate such a condition.
- (h) Improper magneto setting.
- (i) Improper adjustment of valves.
- (j) Lean mixture.
- (k) Excessive spilling of oil into the crankcase or the oil pan due to abnormal clearances within the engine.
- (l) Defective oil thermostat (Model 108-3)

VALVE ROCKER ADJUSTMENT

30. The engine is equipped with hydraulic type valve lifters. The valve lifters adapt themselves to changes in the engine that are caused by wear and by temperature differences. Because of the operation of these hydraulic lifters, valve adjustment is seldom necessary. However, should adjustment become necessary due to change or removal of any of the component parts, proceed as follows:

- (a) With Franklin engine tool No. 11258, bleed all of the oil out of the lifter. Refer to figure 46. When engine tool No. 11258 is

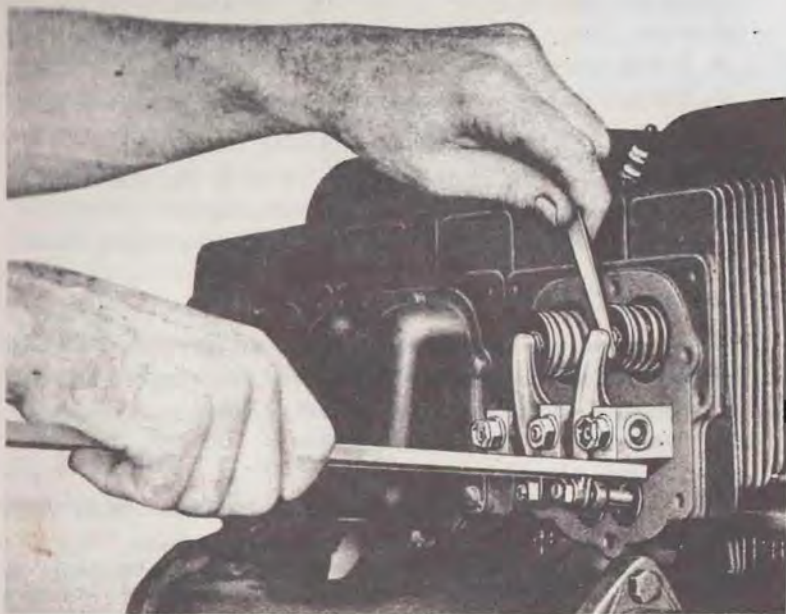

Figure 46—Bleeding Down Hydraulic Valve Lifters

placed on the rocker, and force is applied, movement can be felt as the oil is bled from the lifter. The movement will stop suddenly at a very precise point when the piston bottoms. At this point check the gap between the valve rocker and the valve stem with feeler gauges. At the same time maintain pressure on the bleed down tool.

(b) Make the adjustment by using the rocker adjusting screw and the lock nut. Base the adjustment on the original gap which was found in the check. One complete turn of the adjusting screw will change the gap by approximately .042 inch.

(c) Bleed the lifter down as in step "a" and again check the gap clearance. Repeat steps "a" and "b" until the specified clearance of .040 inch is reached.

ENGINE REMOVAL

31. Remove the engine as follows:

- (a) Remove the propeller.
- (b) Remove the engine cowling.
- (c) Disconnect all wires and lines at the engine.

- (d) Disconnect the cabin air heater duct at the engine.
- (e) Disconnect all controls at the engine.
- (f) Attach a hoist and take up the slack in the hoisting cables.

The engine crankcase is tapped with four holes for the insertion of eye-bolts having $\frac{1}{4}$ inch coarse thread screw ends. The engine may also be hoisted by looping a rope around the starter and another around the forward end of the crankshaft.

- (g) Remove the bolts that attach the engine mount to the firewall.
- (h) Remove the engine and engine mount together.

ENGINE INSTALLATION

32. The following is the procedure for installing the engine (refer to figures 41 through 44):

(a) To install the engine mount on the engine, support the engine with a hoist. Place the engine mount in position under the engine. Install the mounting bolts and the rubber shock mounts. Tighten the bolts through the rubber shock mounts until the distance across the outer faces of the larger metal washers measure $1 \frac{11}{16}$ inches.

(b) Position the assembled engine and mount against the firewall, and install the four bolts through the engine mount and the firewall.

- (c) Install the carburetor and the carburetor air mixing box.
- (d) Attach all lines and wires.
- (e) Attach controls.
- (f) Install the baffles.
- (g) Install the cabin air heater ducts.
- (h) Install the cowl and the carburetor, and connect hot air and cold air intakes.
- (i) Install the propeller and the spinner.

ENGINE CONTROLS

33. The engine controls consist of the ignition switch, the throttle, the mixture control, and the carburetor air heat control. The majority of these are of the push-pull type and no maintenance except an occasional oiling to keep them working freely, is to be anticipated.

ENGINE COOLING SYSTEM

34. The engine is cooled by air that is forced into the engine compartment by the forward speed of the airplane and by the rotation of the propeller. Baffles are installed around and above the cylinders, to direct the cooling air downward between the cylinder

cooling fins. The method of removal and the installation of the baffles is obvious, and requires no special instructions. Maintenance consists principally of inspections to ascertain that the baffles are properly fastened in place, that they are free of cracks and corrosion, and that no extraneous matter is obstructing the openings between the cylinder fins. If the baffles are slightly cracked or corroded, weld or patch the damaged part. If the cracks and/or corrosion are extensive, replace the part.

35. Always have the cowl and the baffles in place before operating the engine for a period of more than a few minutes. The engine will heat rapidly if the cowl and the baffles are not in place, and serious damage to the engine may result.

ENGINE EXHAUST SYSTEM

36. Two corrosion-resistant steel exhaust manifolds are installed. Each manifold receives the exhaust gases of three cylinders, carries the gases back and down, and discharges them into the air stream below the engine cowl. A heater muff is installed on each manifold. The left muff is for the cabin air heater and the right muff is for the carburetor air heater. Maintenance consists principally of inspection of the manifolds to detect cracks and damage. Cracks in either manifold are particularly dangerous as they may introduce carbon monoxide into the cabin heating system or sparks into the carburetor throat. If a manifold leaks where it is attached to the engine, install a new gasket.

CARBURETOR AIR HEATER

37. The air heater supplies heated air to the carburetor when it is desired to prevent the formation of carburetor ice or to eliminate carburetor ice which has formed. The air passes from an intake in the side of the oil cooler fairing, through a muff on the right exhaust manifold, and into the air mixing box. A valve at the mixing box entrance is operated by a push-pull knob on the control panel. To install the muff, slide it on the exhaust manifold.

38. Repair small cracks in the manifold by welding. If cracks are large, replace the manifold.

CARBURETOR AIR FILTER

39. The air filter is an Air Maze No. C-13197. It is installed on the bottom cowl, immediately aft of the oil cooler. To remove the air

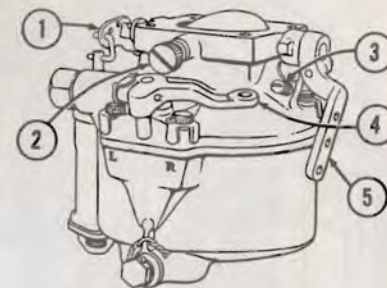

Figure 47—Carburetor

filter, remove the narrow door aft of the oil cooler fairing in the bottom cowl. Pull the air filter down and back.

40. Remove the air filter and wash it in gasoline when the air filter shows signs of dirt accumulation, which may be daily when operating in dusty atmosphere or at least after each 50-hour period of operation. Allow the filter to drain and dry for 20 minutes. Dip the filter in clean engine oil and allow it to drain for 10 minutes. Do not use compressed air to dry the filter element as damage may result. If the filter element is damaged, replace it.

41. Remove air filter for operation during the winter months when there is danger of snow clogging the filter.

42. Install the filter with the vertical ribs on the forward side of the element.

CARBURETOR

43. The Marvel-Schebler model MA-3SPA carburetor on 150 horsepower engines or model MA4-5 on 165 horsepower engines is mounted below and to the rear of the engine. (Refer to figure 47). The carburetor is an up-draft, plain tube, fixed jet type. It incorporates an accelerating pump, a manual mixture control, a double venturi mixing chamber, a fuel inlet strainer assembly, an idle air vent screen, and other improved features.

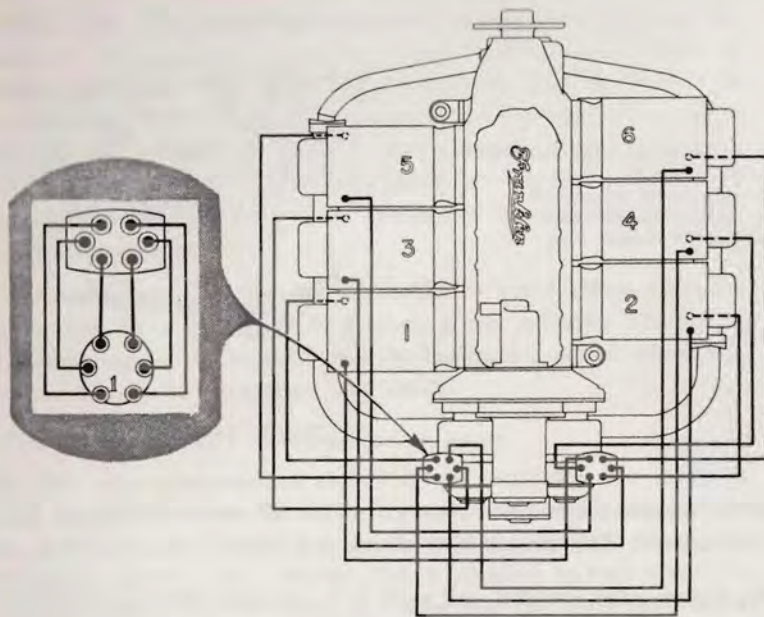
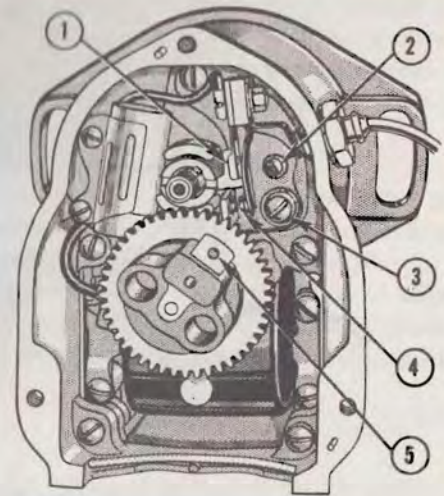

Figure 48—Ignition Wiring Diagram

44. A safety throttle lever spring will hold the throttle in the *open* position for take-off in the event of throttle control failure.

45. The fuel inlet strainer assembly is installed in the carburetor at the fuel inlet. This screen prevents the entry of dirt or foreign matter which might pass the fuel strainer that is mounted on the fire wall.

46. The accelerating pump lever has three holes, into one of which the upper end of the accelerating pump link is fastened. The outer hole, which is approximately midway between the upper and the lower holes, gives the longest stroke, or maximum amount of accelerating fuel. The lower hole gives the shortest stroke, or minimum amount of accelerating fuel. The upper hole provides a medium supply of accelerating fuel. The normal position of the accelerating pump link is in the lower hole, which is the minimum setting. For extremely cold weather or for low test fuel, the upper hole may be necessary for proper acceleration. Rarely, if ever, will the outer hole be required.



1. Fiber Follower
2. Adjusting Cam
3. Lock Screw
4. Point Gap
5. Distributor Rotor

Figure 49—Interior of Eiseman Magneto

CARBURETOR ADJUSTMENT

47. There is little that can go wrong in the adjustment of the carburetor since the main metering characteristics are controlled to a great extent by the fixed jets. Therefore, the only adjustments recommended to be made in the field are those for idle speed and idle mixture. The idle jet operates until the engine is running at about 1000 r.p.m. To make the idle adjustment, proceed as follows:

(a) With the engine thoroughly warmed up, turn the idle adjusting screw, figure 47, in or out until an idle speed of approximately 600 r.p.m. is obtained. It is advisable to run the engine during this adjustment and then allow it to come back to idle speed to make sure that the engine will idle properly in normal operation.

CAUTION

Care should be taken not to damage the idle needle seat by closing the idle adjusting needle too tightly. Damage to this seat will make satisfactory idle adjustment difficult.

(b) Should the engine receive excessive fuel during idling, a heavy black smoke and rolling or surging of the engine will be noted. In this case turn in the idle mixture screw, figure 47, to lean out the mixture. Make this adjustment slowly and in small incre-

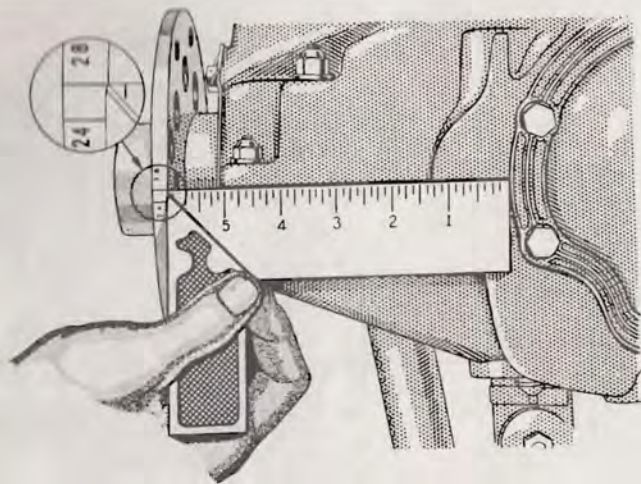

Figure 50—Engine Timing Marks

ments. Wait a few minutes between adjustments to allow the engine to settle out to the new mixture.

(c) Should the idle mixture be lean as indicated by hard starting, by stopping, or by popping in the carburetor, back out the idle mixture screw, figure 47, slowly to richen the mixture. Make this adjustment slowly and with extreme care.

MAGNETOS

48. Ignition is supplied by two magnetos mounted on the rear of the engine crankcase. Either Eisemann model LA-6 or Scintilla model S6RN-21 magnetos are used. The mounting holes in the magneto are slotted to permit rotation of the entire magneto for timing purposes. The right magneto is connected to the upper spark plugs in the left bank of cylinders and to the lower spark plugs in the right bank of cylinders. The left magneto is connected to the lower left and to the upper right spark plugs.

MAGNETO BREAKER POINT SETTING

WARNING

Check to be certain that the ignition switch is *off* and that the magneto ground wires are properly connected. Serious injury is possible if this precaution is not taken.

49. It is essential that the opening of the magneto breaker points be maintained at .019 to .021 inch in order that the ignition will have the proper high-voltage and the correct timing. Always make this adjustment before checking or adjusting the timing of the magneto.

(a) Remove the cover from the magneto.

(b) Turn the magneto over by rotating the propeller in the direction of normal engine rotation until the fiber cam follower is on the peak of the cam lobe as illustrated in figure 49.

(c) Loosen lock screw (1), figure 49, and, by use of adjusting cam (2), adjust the point gap to the specified opening. Tighten lock screw (1) and re-check the gap to be sure that the adjustment has not changed.

MAGNETO TIMING

50. In setting the magneto timing it is best to set the engine at a predetermined point and to adjust the magneto accordingly.

(a) Remove the valve cover from No. 1 cylinder (the left-hand rear cylinder) in order to observe the valve action.

(b) Turn the engine in the normal direction of rotation until the intake valve, which is on the left side of the cylinder when the mechanic faces the valve cover end, has been completely depressed and returned. At this point the piston is on the compression stroke. Continue to turn the engine slowly until the distributor snaps ahead by release of the impulse coupling.

(c) Reverse the rotation until the 28° timing mark for 150 horsepower engines, or 32° for 165 horse-power engines, is just passed and then once more rotate normally until the 28° or 32° timing mark is exactly aligned with the center line of the crankcase. Refer to figure 50.

(d) Loosen the two nuts that hold the magneto to the engine sufficiently to allow the magneto to be turned on the engine by pumping with the heel of the hand or tapping with a soft mallet.

(e) Separate the breaker points just enough to insert a .0015-inch gauge. (Refer to figure 51.) If the feeler gauge is found to be loose, tap the magneto carefully in a counterclockwise direction until the points tighten firmly on the feeler.

(f) Tap the magneto slowly in a clockwise direction until the feeler gauge just loosens.

(g) Tighten the two magneto hold down nuts and check to see

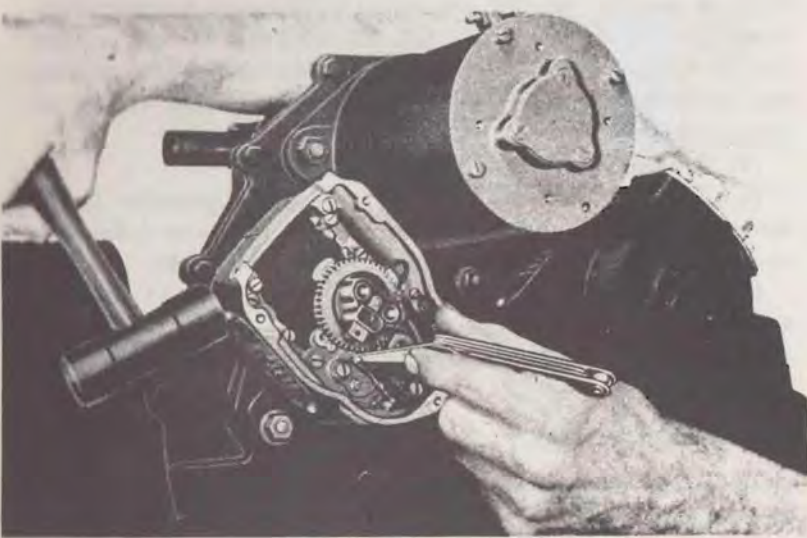

Figure 51—Magneto Timing

that the feeler gauge still indicates the same setting. The magneto is now properly timed.

- (h) Replace magneto cover and wires.
- (i) Replace the valve cover on No. 1 cylinder.

SPARK PLUGS

51. Twelve Champion type J-10 or Auto-Lite AH-4 spark plugs are installed.

52. As indicated in the inspection procedure, at each 100-hour inspection period clean and gap the spark plugs. The correct gap is .014 to .018 inch. Before making any repair to a spark plug, make a visual check of the electrodes. If burning has materially reduced the size of either electrode, discard the spark plug. If the condition of the spark plug warrants reworking and reinstallation in the engine, proceed as follows:

(a) Soak the entire plug in a suitable solvent that has been checked to ascertain complete absence of oil of any type. If a coating of oil is left on the spark plug by the solvent, the oil will cause

blasting material to pack in the small crevices in the lower portion of the spark plug.

(b) Thoroughly remove the solvent and whatever dirt it may have loosened from the spark plug. Completely dry the spark plug. If sandblasting is necessary, keep it to a minimum consistent with thorough cleaning. Sandblasting tends to roughen and erode the electrodes and this leads to more rapid burning, as well as to carbon deposit.

(c) Reinstall the spark plug with a solid copper gasket. Use care not to cross the threads. Tighten the plug to a torque of from 12 to 15 foot-pounds.

IGNITION SYSTEM MAINTENANCE

53. The maintenance of the ignition system is accomplished during periodic inspections. Keep the ignition wiring free of loose connections, damaged spark plug leads, and damage due to chafing. Make certain that all magneto ground connections are tight and that there are no loose terminals. Check the ground wires back to the ignition switch to determine that connections are tight. Keep all insulators free of moisture, dirt, oil, and grease. Refer to figure 48 for information on wiring from the magnetos to the spark plugs. Refer to figures 59 and 60 for information on wiring from the ignition switch to the magnetos.

OIL SYSTEM

54. The engine is a wet sump type. Eight quarts of oil are carried in the 150 horsepower engine crankcase and nine quarts in the 165. A minimum of four and five quarts respectively is required for engine operation. At temperatures above 40°F use oil, SAE No. 40. At temperatures below 40°F use oil, SAE No. 20. A dip stick for measuring the quantity of oil in the engine is accessible upon lifting the right engine cowl panel. The stick is on the top right side of the engine crankcase, inside the baffle. A separate dip stick is available for seaplanes which should be used because of the level ground altitude of the airplane. For full throttle operation of the engine, the oil temperature limits are from 60 to 230°F and the oil pressure limits are from 35 to 55 p.s.i.

OIL COOLER

55. An oil cooler is installed in the bottom cowling. Maintenance

of the oil cooler is seldom necessary. Keep the oil line hose clamps tight and in the proper locations. In case the oil temperature rises without an apparent cause, remove the oil cooler and inspect for obstructions.

56. Some early type engines are equipped with oil coolers that have a pressure relief valve to by-pass oil around the cooler in case the cooler is clogged. These engines have an oil pressure regulating valve installed inside the crankcase, at the oil pump.

57. Model 108-3 airplanes are also equipped with a thermostat built into the oil cooler.

OIL PRESSURE RELIEF ADJUSTING VALVE

58. All later type engines have an oil pressure relief adjusting valve that is installed on the front left side of the engine. The valve is in the housing that contains the ports for the oil cooler lines. This valve controls the amount of oil pressure and also acts as a by-pass valve to by-pass oil around the oil cooler in case the oil cooler becomes clogged. These engines do not have an oil pressure regulating valve inside the crankcase.

59. The valve is adjusted at the factory and should not require adjustment in the field. However, if it becomes necessary to adjust the valve, the procedure is as follows:

(a) To increase oil pressure, remove the nut and the shim under the adjusting spring, and reinstall the nut.

(b) To decrease oil pressure, remove the nut and replace the spring with one that will give the desired oil pressure, then reinstall the nut.

(c) In case oil pressure is low without apparent cause, disassemble the valve, clean thoroughly, and reassemble. Small particles of dirt or foreign matter can lodge in the valve mechanism and prevent proper operation.

OIL SYSTEM MAINTENANCE

60. Drain the oil after each 25-hour period of operation. Where unusually dirty or sandy conditions of operation prevail, it will probably be necessary to drain the oil more often. Before discarding the oil, strain it through a screen, 20 mesh, or finer, to make certain that no metallic particles are present. The presence of metallic particles serves as a warning that some part in the interior of the

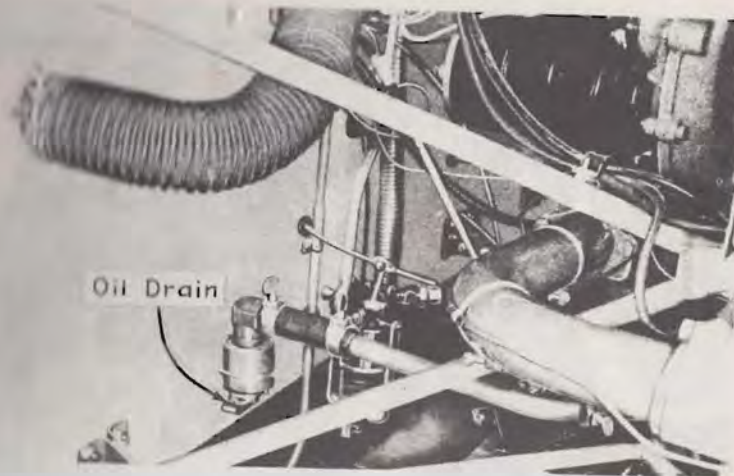

Figure 52—Oil Drain

engine requires attention. Normally an engine should give many hundreds of hours of service before any metallic particles appear.

61. Metal particles are usually present in oil drained from a new engine, but this does not indicate wear of engine parts. If metal particles are found in oil drained from an engine that has been in service for some time, however, wear of parts should be suspected and the engine should be checked to determine the cause.

DRAINING OIL

62. Before draining the oil from the engine crankcase, run engine until oil reaches the normal operating temperature. On the models 108 and 108-1 airplanes it is recommended that a trough be provided to flow the oil from the drain plug aft and away from the engine cowl. On the models starting with 108-2, an oil drain system is provided. Push slide of valve mounted on the firewall to one side to drain the oil in this system. Always be sure to reinstall safety wire on drain valve slide after draining the oil.

FUEL SYSTEM

63. The fuel system is the gravity type. (Refer to figure 53.) A tank having 20 gallons capacity is installed in each wing panel of

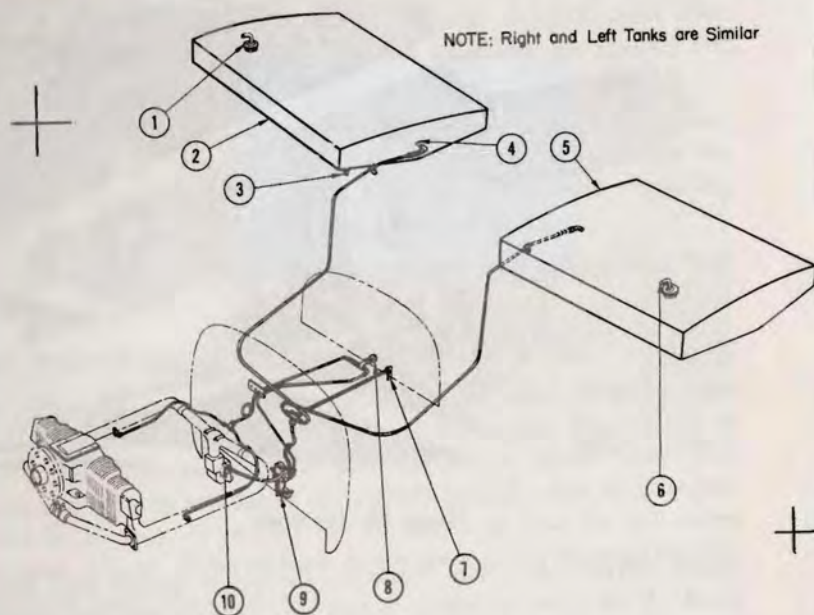

- | | |
|--------------------------|----------------------------------|
| 1. Right Filler Cap | 6. Left Filler Cap |
| 2. Right Tank | 7. Selector Valve Control Handle |
| 3. Drain Plug | 8. Engine Primer Pump |
| 4. Fuel Strainer in Tank | 9. Fuel Strainer on Firewall |
| 5. Left Tank | 10. Fuel Strainer in Carburetor |

Figure 53—Fuel System

the models 108, 108-1, and 108-2. The tanks in the model 108-3 have a capacity of 25 gallons each. All but two gallons of the fuel in each tank is available for use in flight. The weight of these two gallons (four gallons per airplane) is included in the weight empty of the airplane.

64. A strainer is installed in the fuel outlet of each tank. From each tank outlet a fuel line leads to the fuel selector valve, mounted under the instrument panel; from the fuel selector valve a line leads to a fuel strainer mounted on the right forward face of the firewall; and from the fuel strainer a line leads to the carburetor intake port.



Figure 54—Fuel Strainer

65. The engine primer line leads from the fuel strainer to the primer pump mounted on the instrument panel. From the primer pump, primer lines lead to the intake manifolds.

66. An electrical fuel quantity gauge is mounted on the instrument panel. A transmitter unit that is electrically connected to the fuel quantity gauge is installed in each fuel tank.

FUEL TANKS

67. The tanks are welded assemblies of 2S 1/2 H aluminum alloy. (Refer to figure 55.) One tank is installed in each wing. The tank is placed in the wing from the top. The upper lips of the tank rest on the spars and are padded with .38 x 1.00-inch neoprene and cork strips. Each tank is held in place with two straps over the top. These straps are fastened with bolts at the rear spar. The top of the tank conforms to the contour of the upper surface of the wing. Be careful not to dent or buckle the upper surface of the tank when handling.

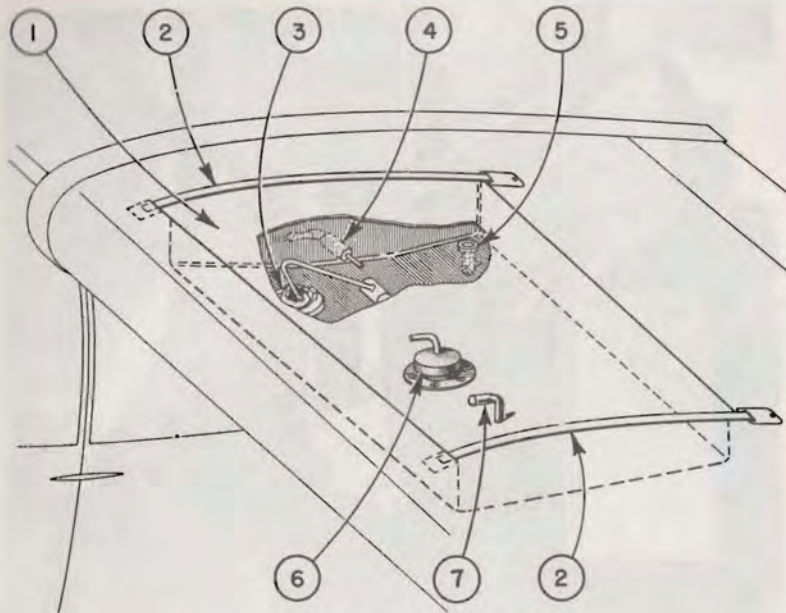

- | | |
|---------------------------|----------------|
| 1. Tank | 4. Fuel Outlet |
| 2. Hold-Down Strap | 5. Drain |
| 3. Fuel Level Transmitter | 6. Filler Cap |
| 7. Vent (Model 108-3) | |

Figure 55—Fuel Tank

68. An access opening in the forward inboard corner of the bottom of the wing cover is provided for the removal or the installation of the fuel quantity transmitter unit. A drain is installed in the rear inboard corner of the bottom of the tank for bleeding water and draining the tank.

69. The filler cap is installed in the top of the tank. Filler caps having the tank vent built into them should always be installed with the vent pointing forward.

FUEL TANK REMOVAL

70. Remove the fuel tank as follows:

- (a) As a precaution against fire, ground the airplane, the fuel

tank, and the container into which the fuel is to be drained; then drain the tank.

- (b) Detach the wire to the fuel quantity transmitter unit.

(c) From above, detach the fuel line from the elbow in the wing-to-fuselage gap.

- (d) Remove the wing fabric that covers the tank.

- (e) Remove the two straps that hold the tank in place.

- (f) Remove the tank.

FUEL TANK REPAIR

71. Remove the tank from the airplane before starting any repair work that requires the application of heat.

72. Drain and thoroughly clean the tank if it is to be welded or if an open flame is to be used in the repair. Flush the tank with hot water that is admitted at the bottom and that is allowed to overflow at the top of the tank. The hot water will remove deposits of fuel that adhere to the inside of the tank. To clean the tank, pass *live steam* through the tank from top to bottom for three hours. Do not expect steam vapor (as distinguished from *live steam*) to clean the tank sufficiently to prevent combustion while the tank is being welded.

73. When tank repairs can be made by soldering with a soldering iron (not a flame) it is not necessary to steam-clean the tank. Flush the tank, however. Do not heat the soldering iron to the point where it can cause particles of dust to become incandescent.

74. Corrosion indicates that there are impurities in a tank. When corrosion is present, remove the tank. Use *live steam* to remove all fuel, then clean it with nitric acid and sodium chromate in a hot steam solution of 35 to 30 percent of sodium chromate by weight. Keep the tank one-third full for one hour then flush with fuel.

75. Burnish light scratches. Weld deep scratches and dents.

76. After any repair to fuel tank, make a pressure test. Apply 1.5 p.s.i. of air while the tank is immersed in water.

FUEL TANK INSTALLATION

77. Following is the procedure for installing a fuel tank:

CAUTION

Handle the tank with care so as not to dent or buckle the upper surface.

- (a) Check to be sure that the .38 x 1.00-inch cork strips are installed.
- (b) Install the tank in the wing panel from the top.
- (c) Install the two hold down straps and tighten the bolts.
- (d) Replace the wing fabric that covers the tank.
- (e) Connect the fuel line hose at the elbow in the wing-to-fuselage gap.
- (f) Connect the wire to the fuel quantity transmitter unit.
- (g) Fill the tank with fuel, and inspect the tank and fuel line for leaks.

FUEL SELECTOR VALVE

78. The fuel selector valve is mounted on the cabin side of the firewall and is controlled by a shaft and handle extending through the control panel. This valve can be turned to supply fuel from either of the two wing tanks, or it can be turned *off* by turning the handle so that the pointer is down.

ENGINE PRIMER

79. The primer pump is mounted immediately below the control panel, below the throttle. To prime the engine, pump the knob. Fuel for priming is drawn from the fuel strainer on the engine side of the firewall and pumped into each engine intake duct on the sides of the engine.

80. To check the engine primer, disconnect the lines from the intake ducts on each side of the engine. Pumping primer should cause fuel to squirt from these lines.

**CHAPTER VII
ELECTRICAL SYSTEM**

GENERAL

1. The electrical system of these airplanes is a 12-volt, direct-current, single wire system. (Refer to figures 56 through 59). All electrical equipment is grounded to the metal structure of the airplane, and this structure takes the place of the second wire which would otherwise be required. The battery stores electrical energy and is the source of power when the generator is not operating. When the generator is operating, it is a source of power and also charges the battery. Both the battery and the generator are connected to a bus bar. All electrical equipment, except the starter, is powered from the bus bar. The starter is powered from the load side of the battery relay. Figures 58 and 59 illustrates the electrical wiring and connections.

2. The master switch, located on the control panel, controls the battery relay and the generator field circuit. This switch must be *on* before any of the electrical equipment will operate. When the master switch is placed in the *on* position, the bus bar is energized and power is available for all circuits of the airplane. When *on* it also closes the generator field circuit and makes it possible for the generator to produce electrical power as the engine operates.

3. The ignition is independent of the electrical system, except that the ignition switch controls the operation of the starter. The starter will not operate unless the master switch is *on*.

BATTERY

4. In the models 108, 108-1, and 108-2, the battery is mounted in a vented case located beneath the pilot's seat. Either the Exide battery No. 6TS-9F or the Willard battery AW-12-25 may be used. The case is provided with a vent and a drain tube which carries fumes and overflow liquids outside and below the fuselage.

5. In the model 108-3, the battery is mounted on the forward side of the firewall in the engine compartment. This battery must be the Willard No. AW-12-25 equipped with a manifold vent. The vent tube is directed down the fire wall, under the cabin floor, and down the landing gear leg.

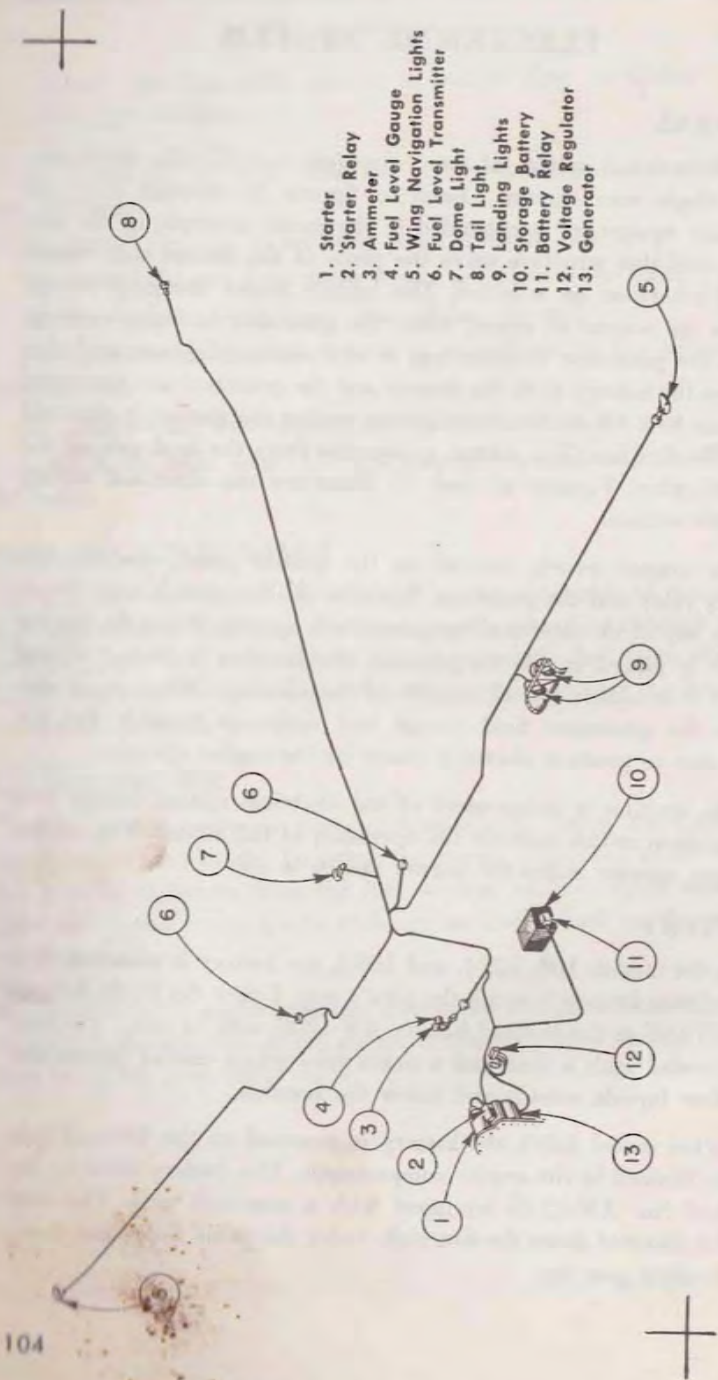

1. Starter Relay
2. Starter
3. Ammeter
4. Fuel Level Gauge
5. Wing Navigation Lights
6. Fuel Level Transmitter
7. Dome Light
8. Tail Light
9. Landing Lights
10. Storage Battery
11. Battery Relay
12. Voltage Regulator
13. Generator

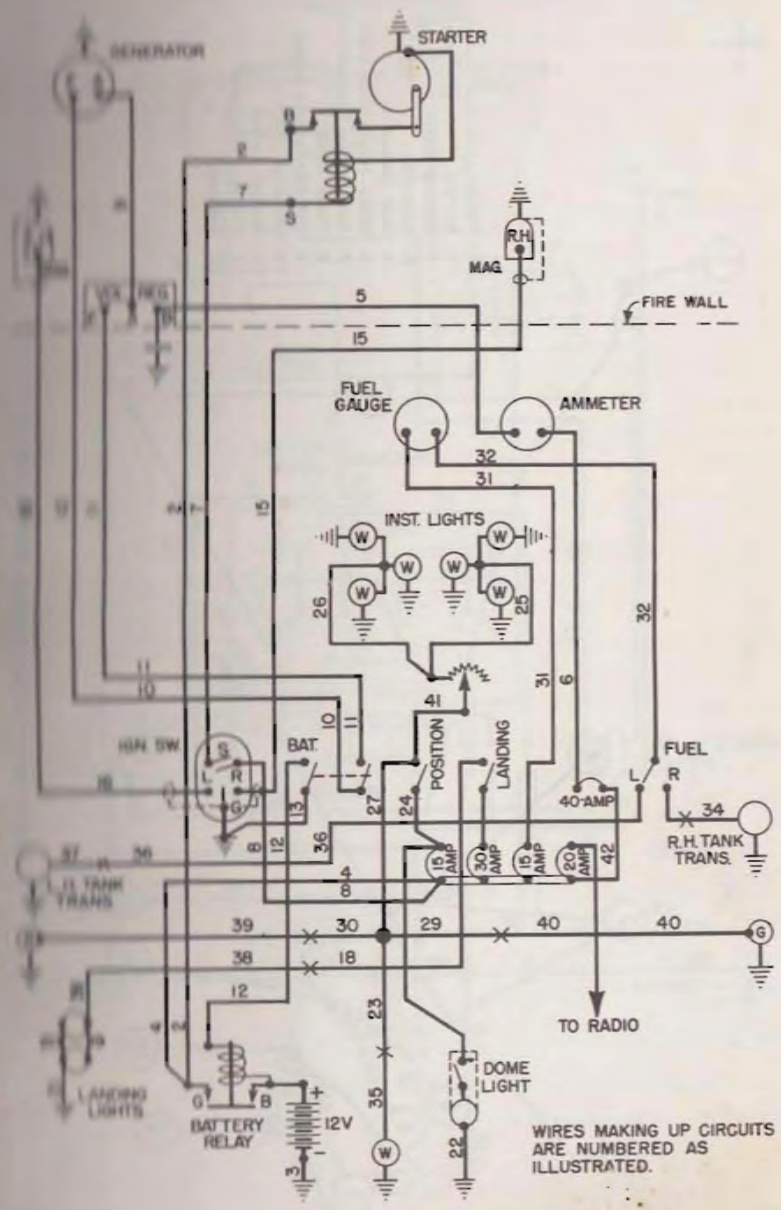

WIRES MAKING UP CIRCUITS ARE NUMBERED AS ILLUSTRATED.

Figure 57—Electrical Wiring Diagram (Models 108, -1, -2)

1. Starter
2. Battery
3. Battery Relay
4. Ammeter
5. Fuel Gauge
6. Wing Navigation Light
7. Fuel Gauge Transmitters
8. Dome Light
9. Tail Navigation Light
10. Landing Lights
11. Master Switch
12. Voltage Regulator
13. Generator

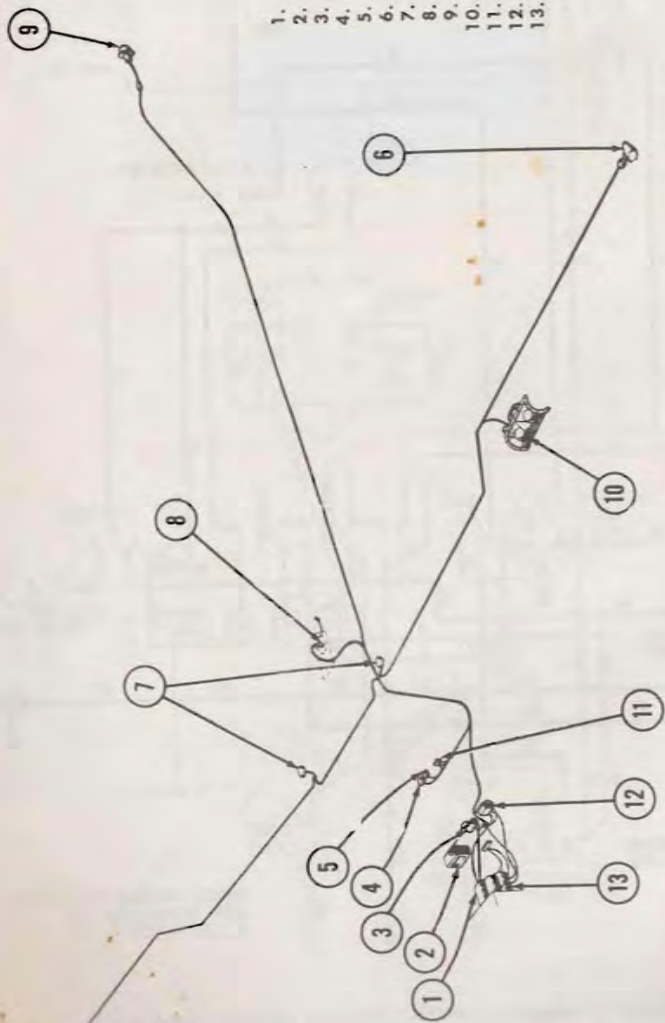

Figure 58—Electrical System (Model 108-3)

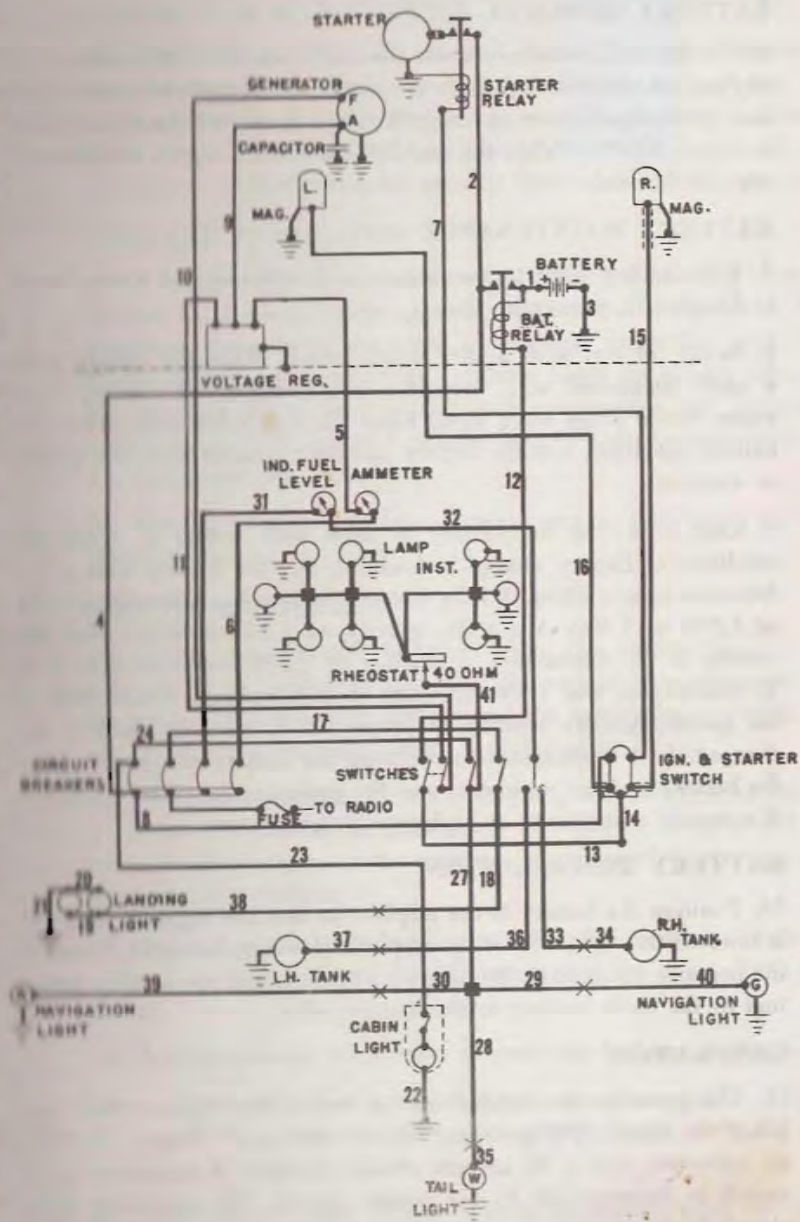

Figure 59—Electrical Wiring Diagram (Model 108-3)

BATTERY REMOVAL

6. To remove the battery from the early models it is necessary to tilt back the pilot's seat. Slide the seat full forward and remove the seat track stop bolt on the right forward corner of the seat. (Refer to figure 8.) Then slide the seat full aft and lift up on the forward edge of the seat.

BATTERY MAINTENANCE

7. Keep battery filled to the proper level with distilled water. Refer to Chapter 11, paragraph 13.

8. Brush off dirt with a stiff bristle brush. Wipe the battery with a cloth dampened with ammonia water. Rinse the battery with water. Screw plugs down tight. Keep the vent holes clear. After the battery has dried, coat the battery and the terminals with thin grease or vaseline.

9. Each time that the battery is filled with water, or when the condition of battery charge is doubtful, test the battery with a hydrometer before filling. A fully charged battery has a specific gravity of 1.275 to 1.300. A specific gravity of 1.240 indicates that the battery is $\frac{1}{3}$ discharged, a reading of 1.200 indicates that it is $\frac{2}{3}$ discharged, and 1.150 indicates it is completely discharged. If the specific gravity reading is below 1.250, have the battery recharged. If it is necessary to recharge the battery frequently, have the battery, voltage regulator, and the generator tested to determine if a repair, adjustment, or replacement is necessary.

BATTERY INSTALLATION

10. Position the battery in the airplane so that the negative terminal is towards the right side of the airplane (looking forward). Connect the negative terminal to the aircraft structure, and the positive terminal to the cable leading to the battery relay.

GENERATOR

11. The generator is installed on the rear of the engine crankcase, below the starter. The generator circuit contains a voltage regulator, an ammeter, and a 40 ampere circuit breaker. A generator field switch is incorporated in the master switch. The generator field circuit is closed when the master switch is *on* and is open when the master switch is *off*.

GENERATOR MAINTENANCE

12. Clean dirt, carbon dust, oil, and grease from the commutator and brushes. If the commutator is scored, worn unevenly, or has low bars, remove the generator and overhaul it. Replace the brushes when they are worn to within $\frac{1}{8}$ inch of the brush holders. Be sure that generator blast tubes are securely fastened to the generator case.

VOLTAGE REGULATOR

13. A voltage regulator is mounted on the left forward side of the firewall in all airplanes except some model 108-2 airplanes. In those airplanes, the voltage regulator is mounted under the pilot's seat beside the battery. The voltage regulator holds the output voltage of the generator to a constant rate and compensates for changes in engine speed. The constant voltage insures that the generator will not overcharge the battery.

14. When the voltage regulator requires service, take it to a certified repair station.

CIRCUIT BREAKERS

15. Circuit breakers are installed under the control panel at the left. (Refer to figures 46 and 47). The circuit breakers protect all circuits except the starter circuits and the battery-to-bus circuit. On the model 108-3 the radio circuit is protected by a fuse.

16. The circuit breakers automatically trip and re-set when there is an overload condition in the circuit. The circuit breaker will give intermittent operation of the units in a circuit until the faulty circuit condition is corrected.

17. A 15-ampere circuit breaker protects the navigation light circuits, the instrument panel light circuit, and the cabin dome light circuit.

18. A 15-ampere circuit breaker protects the fuel gauge circuit.

19. A 20-ampere circuit breaker protects the circuit to the radio on the models 108, 108-1 and 108-2. A 10-ampere fuse protects the radio circuit on the model 108-5.

20. A 30-ampere circuit breaker protects the landing light circuit.

21. A 40-ampere circuit breaker protects the generator circuit.

STARTER

22. A direct-drive electric starter is mounted on the rear of the engine crankcase. The starter relay is mounted on the starter.

STARTER MAINTENANCE

23. Clean dirt, carbon dust, oil, and grease from the commutator and from the brushes. If the commutator is scored, worn unevenly, or has low bars, it should be removed and overhauled. Replace the brushes when they are worn to within $\frac{1}{8}$ inch of the brush holders.

LIGHTS

24. There are three navigation lights, six instrument panel lights on the models 108, 108-1, and 108-2, (eight instrument panel lights on the model 108-3), one cabin dome light, and two landing lights. For type of bulbs used, refer to the list of electrical equipment

25. Replace the navigation and the landing light bulbs when discoloration of the bulbs become appreciable. As these bulbs age, the deposits of filament evaporation on the bulb inner surface will reduce light output by as much as 15 percent. Keep the inside and outside surfaces of the protective cover glasses clean. For care of the Plexiglas cover over the landing lights, refer to Chapter 111.

LIST OF ELECTRICAL EQUIPMENT

<i>Unit</i>	<i>Type</i>	<i>Location</i>
Generator, 12-volt	Delco-Remy 1101877	On engine
Voltage regulator 12-volt, 24 to 26-amperes	Delco-Remy 1118263	On forward face of firewall or under pilot's seat
Starter, 12-volt	Delco-Remy 1109651	On engine
Starter relay	Furnished with starter	On starter
Magnetos (2)	Eisemann LA-6 or Scintilla S6RN-21	On engine
Fuel level indicator gauge	A-C Spark Plug 1516893	Instrument panel
Ammeter	A-C Spark Plug 1500806	Instrument panel
Ignition switch	Delco-Remy 1994524	Control panel
Master switch	Cutler Hammer 8822K3	Control panel
Fuel level indicator gauge switch	Cutler Hammer AN 3021-3	Control panel
Position (navigation and instrument panel lights) switch	Cutler Hammer AN 3021-2	Control panel

LIST OF ELECTRICAL EQUIPMENT (Cont'd)

<i>Unit</i>	<i>Type</i>	<i>Location</i>
Landing (lights) switch	Cutler Hammer AN 3021-2	Control panel
Fuel level transmitters	A-C Spark Plug 1516894	In fuel tanks
Circuit breaker, 15- ampere (fuel gauge)	Spencer CA-15	Below control panel
Circuit breaker, 15- ampere (navigation, instrument panel, and cabin dome lights)	Spencer CA-15	Below control panel
Circuit breaker, 20-ampere (radio)	Spencer CA-20	Below control panel
Fuse, 10-ampere (radio)		Below control panel
Circuit breaker, 30-ampere (landing lights)	Spencer CA-30	Below control panel
Circuit breaker, 40- ampere (Generator)	Spencer CA-40	Below control panel
Lights, navigation (2)	Grimes Mfg. Co. A1285	Left wing tip, red Right wing tip, green
Bulbs (2)	Grimes Mfg. Co. A1243	
Light, navigation, tail	Grimes Mfg. Co. A2064	Rudder trailing edge, white
Bulb	G-E 93	
Lights, landing (2) (Sealed Beam)	G-E 4509	Left wing panel lead- ing edge
Light, cabin dome	C. Cowles Co. 52 or C. M. Hall Lamp Co. A10461	Cabin ceiling
Bulb	G-E 89	
Bulbs, instrument panel (6 or 8)	G-E 53	Instrument panel
Storage battery, 12-volt	Electric Storage Battery Co. 6TS-9F or Willard AW-12-25	Under pilot's seat or on forward face of firewall
Battery relay	R.B.M. Mfg. Co. 70-111052	With battery
Rheostat, 40-ohm (instrument panel lights)	Ohmite Mfg. Co. model D	Below control panel
Condenser, 2-MFD, 50-volt	Industrial Condenser Corp.	On firewall near voltage regulator



The Model 108

CHAPTER VIII

HEATING AND VENTILATING SYSTEM

HEATER (Model 108)

1. Heat for the cabin in the model 108 is provided by a hot-air heater installed on the left exhaust manifold. As illustrated in figure 60, fresh air enters an air intake in the nose cowling and passes through a flexible tube to a muff on the left exhaust manifold. All or a part of the air which has been heated in passing through the muff can be delivered into the cabin by means of a valve controlled by a push-pull knob on the right side of the control panel. When the valve is completely closed, all of the heated air is discharged outside the airplane. When the valve is opened, heated air passes through a flexible tube and enters the cabin through a port in the firewall. The port, located just above the floor near the center of the firewall, has an adjustable metal cover plate. Directional control of heated air that enters the cabin can be obtained by turning the cover plate to the right or to the left.

HEATER (Models 108-1 and up)

2. Starting with the model 108-1 the heater system is enlarged to provide either heated or fresh-air, or a mixture of the two, to three ports in the cabin. Refer to figure 61. Each of the three ports may be individually closed to modify the distribution of air in the cabin.

HEATER MAINTENANCE

3. If the exhaust manifold should become cracked, carbon monoxide fumes may be discharged into the cabin; consequently, the heater muff should be removed occasionally so that the manifold can be inspected for leaks.

4. Check the operation of the push-pull knob to make certain that the valve door functions properly. When the knob is pulled all the way out, the valve door should be open completely to permit all the heated air to flow into the cabin. When the knob is pushed all the way in, the valve door should shut off the flow of heated air into the cabin and vent the heated air into the engine compartment.

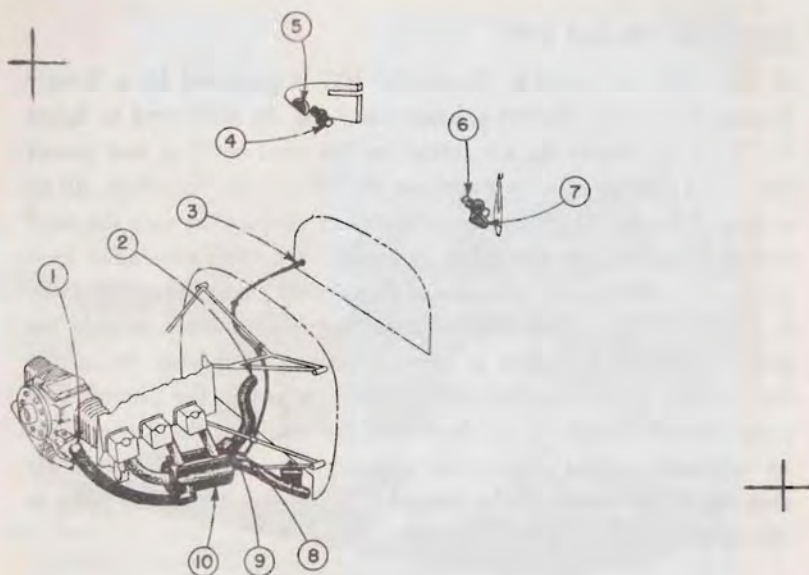

- | | |
|----------------------------|--------------------------|
| 1. Air Intake Duct | 6. Left Ventilator |
| 2. Cabin Heat Duct | 7. Ventilator Air Intake |
| 3. Cabin Heat Control Knob | 8. Cabin Heat Control |
| 4. Right Ventilator | 9. Heater Valve |
| 5. Ventilator Air Intake | 10. Heater Muff |

Figure 60—Cabin Heating and Ventilating Systems (Model 108)

HEATER MUFF REMOVAL

5. If for any reason the air intake or the duct to the heater muff is removed, the heater muff must also be removed. The procedure for removing the heater muff is as follows:

- (a) Remove the clamps and disconnect the air intake tube at the muff.
- (b) Remove the clamps and disconnect the cabin heated air intake tube at the heater valve.

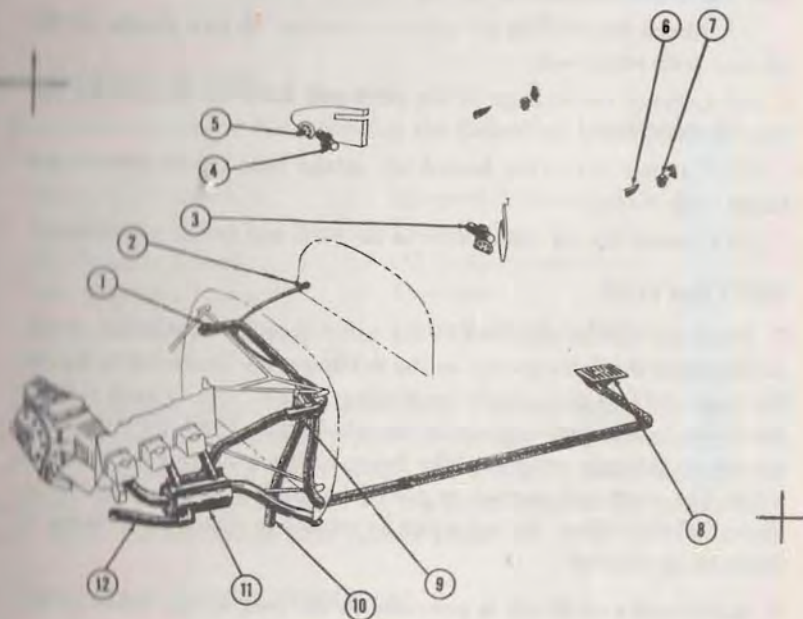

- | | |
|--------------------------------|--------------------------|
| 1. Right Heater Port Duct | *7. Left Rear Ventilator |
| 2. Cabin Heat Control | 8. Rear Heater Port |
| 3. Left Front Ventilator | 9. Heater Control Valve |
| 4. Right Front Ventilator | 10. Fresh Air Intake |
| 5. Front Ventilator Air Intake | 11. Heater Muff |
| 6. Rear Ventilator Air Intake | 12. Hot Air Intake |

*On Model 108-3 Only

Figure 61—Cabin Heating and Ventilating Systems (Models 108-1, -2, -3)

(c) Disconnect the linkage to the push-pull knob at the arm on the valve door. (Model 108 only.)

(d) Remove the safety wire at two places on the aft end of the muff and slide the retaining channels back and off the exhaust stack.

HEATER MUFF INSTALLATION

6. The procedure for installing the heater muff is as follows:

(a) Position the heater muff and slide the retaining channels onto the exhaust manifold from the rear.

(b) Attach the muff to the exhaust manifold at two places, on the aft end, with safety wire.

(c) Connect the linkage to the push-pull knob at the arm on the valve door. (Model 108 only.)

(d) Connect the cabin heated air intake tube at the heater and fasten with clamps.

(e) Connect the air intake tube at the muff and fasten with clamps.

VENTILATION

7. Fresh air can be supplied to the cabin through ventilators or by sliding back the front panels on the windows. As illustrated in figure 60, there are two ports in the ventilating system, one on each side of the cabin in the upper corners of the windshield. Fresh air flows into the cabin through screened inlet holes in the leading edge of each wing. The ports are opened or closed by pulling out or pushing in the cylindrical tubes; the tubes can be rotated to direct the streams of fresh air as desired.

8. Additional ventilation is provided in the rear of the cabin in the model 108-3 by two ports in the upper window sill. These ports are similar to those used at the front of the cabin. Refer to figure 61.

CHAPTER IX

INSTRUMENTS

INSTRUMENT PANEL

1. Provisions are made for mounting the following instruments in the instrument panel:

Magnetic Compass	Airspeed Indicator
Altimeter	Tachometer
Oil Pressure Gauge	Oil Temperature Gauge
Fuel Quantity Indicator	Ammeter
Bank & Turn Indicator	Vertical Speed Indicator
	Clock

2. The instrument panel is provided with indirect lighting. Light from the instrument lights reflects against the inner side of the cover panel and illuminates the instruments. The intensity of the light is controlled by a rheostat mounted on the lower edge of the control panel, below the carburetor heat control knob.

INSTRUMENT PANEL REMOVAL

3. To remove the instrument panel:

- Remove the indirect lighting mask from the panel.
- Remove all the screws that attach the instrument panel.
- Support the panel from below and tilt it forward so that the backs of the instruments can be seen from the top. Disconnect all lines and wires from the instruments. The light bulbs may be pulled out of the panel and need not be disconnected.

CAUTION

Use care when disconnecting the oil pressure line. The line is filled with light oil.

INSTRUMENT PANEL INSTALLATION

4. To install the instrument panel:

- Set the bottom of the panel in place. Tilt the panel aft so that the backs of the instruments are visible from the top.

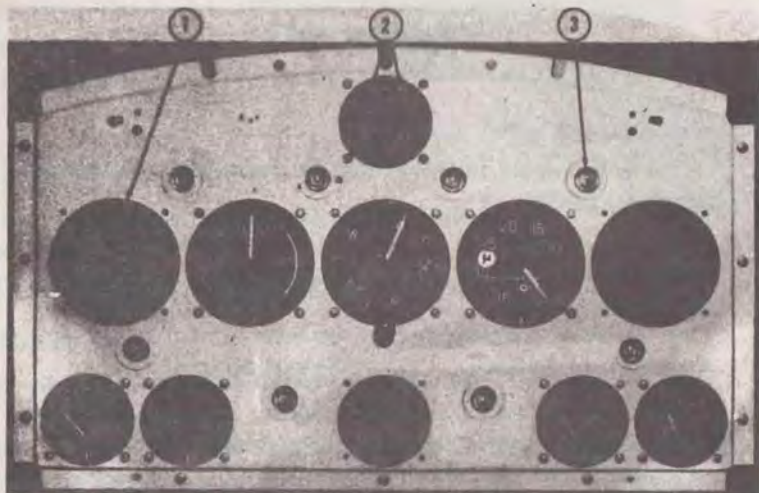

1. Holes for Additional Instruments 2. Compass Compensation Screws
3. Light

Figure 62—Instrument Panel

(b) Make all hose and electrical connections to the instruments. Be especially careful to connect the pitot and static hoses to the proper ports on the airspeed indicator. Refer to Wiring Diagrams, figures 57 and 59 for correct electrical connections.

(c) Fasten the panel in place with screws around the panel flange.

(d) Install the indirect lighting cover over the face of the instrument panel.

AIRSPEED INDICATOR MAINTENANCE

5. The accuracy of the airspeed indicator depends on proper maintenance of the pitot-static tube and lines. Refer to figure 63. Keep these lines clear of water by periodically opening the hose connections under the left side of the instrument panel and bleeding out the water accumulation. The frequency of this operation will depend on atmospheric conditions.

6. Check the lines for leaks with the pitot and static lines connected.

CAUTION

Before testing the airspeed indicator lines, disconnect the altimeter hose at the static line T-fitting and plug the hole.

To test the lines for leaks, proceed as follows:

(a) Fasten a rubber bulb over the pitot head.

(b) Apply air pressure until the air-speed indicator registers 100 m.p.h. Hold at this pressure for five seconds to determine if the speed indication decreases.

(c) If the speed indication starts to decrease before five seconds, look for leaks in the lines or in the instrument cover seal.

(d) Squeeze all the air out of the rubber bulb and attach it to the static head of the pitot-static tube.

(e) Apply suction to the static line until the pointer on the air-speed indicator shows the maximum air-speed indication; hold the suction for five seconds. If the indication decreases more than three miles per hour during this time, look for leaks in the static line or in the instrument case.

(f) After testing the lines for leaks with the air-speed indicator connected, disconnect the instruments and clean both lines by blowing compressed air through them. Attach the air hose at the pitot and static heads.

COMPASS COMPENSATION

7. Compensate the compass and make out a new correction card every four months. The compass compensating screws are illustrated in figure 62. Use a non-magnetic screw driver.

8. When compensating the compass, it is recommended that the airplane be maintained in the following status:

Elevator and aileron controls in *neutral*.

Engine operating at sufficient speed to indicate a maximum generator charging rate.

Radio *off*.

Turn and bank indicator (in airplanes so equipped) *on*.

9. Compensate the compass as follows:

(a) Head the airplane due north, according to a master compass or a compass rose.

- Tachometer Shaft
 1. Tachometer Shaft
 2. Altimeter
 3. Airspeed Indicator
 4. Static Line
 5. Pitot Pressure Line
 6. Drain
 7. Oil Temperature Gauge Line
 8. Oil Pressure Gauge Line

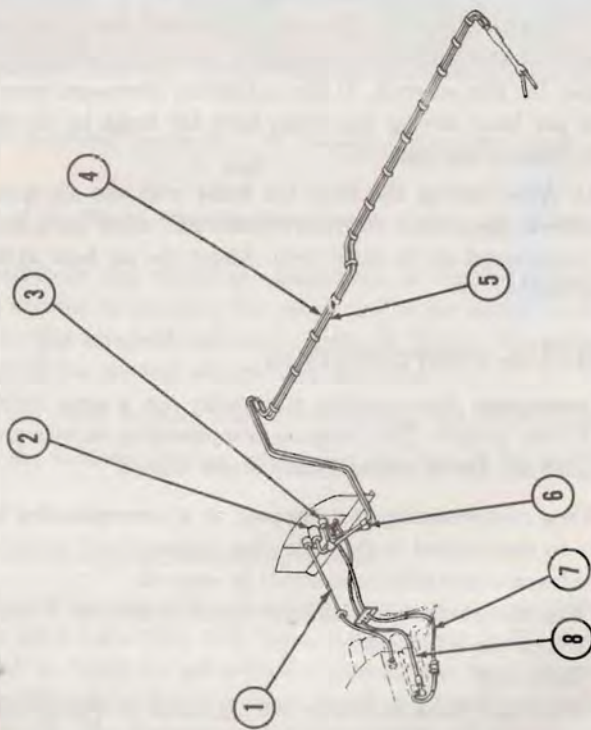

Figure 63—Instrument Lines

(b) Turn the "N-S" screw, using a nonmagnetic screw driver, until the compass shows a north reading.

(c) Turn the airplane south.

(d) Turn the "N-S" screw until one-half the error is accounted for.

(e) Head the airplane east and turn the "E-W" screw until the compass shows an east reading.

(f) Turn the airplane west, and compensate for one-half the error.

10. After compensation, check points of the compass with position and instrument light on. Check also effect of moving the elevator control wheels through their full travel. This may be expected to produce some compass deviation, but should it exceed 20 degrees over the full travel range of the control wheels, it is recommended that the control wheels and shafts be removed from the airplane and demagnetized.

INSTRUMENT MARKINGS

11. The airspeed indicator, tachometer, oil pressure gauge, and oil temperature gauge must be marked to indicate the operating range of the engine and airplane. Original instruments, in many cases have these markings on the dial. Replacement instruments, if not properly marked, can be marked by painting the lines on the cover glass of the instrument. The lacquer used should be of colors equivalent to those prescribed by ANA Bulletin No. 165. The colors are Insignia Red, No. 509; Insignia White, No. 511; Light Green, No. 503; and Orange Yellow, No. 506. All lines are $\frac{1}{16}$ inch wide.

12. When the instrument markings are on the cover glass, make a short white index line from the bottom of the glass across the edge of the instrument case, so that any turning movement of the glass and displacement of the markings can be detected.

13. THE OIL TEMPERATURE GAUGE is marked with a yellow arc from 60 to 80, a green arc from 80 to 230, and a red radial line at 230.

14. THE OIL PRESSURE GAUGE is marked with a green arc from 35 to 55 and red radial lines at 35 and 55.

15. THE TACHOMETER in the models 108 and 108-1 is marked with a green arc from 2000 to 2600 and a red radial line at 2600.

16. THE TACHOMETER in the models 108-2 and 108-3 is marked with a green arc from 2000 to 2800 and a red radial line at 2800.

17. THE AIRSPEED INDICATOR in the models 108 and 108-1 is marked with a white arc from 57 to 88, a green arc from 60 to 117, a yellow arc from 117 to 158, a red radial line (marked "N") at 148, and a red radial line (marked "U") at 158.

18. THE AIRSPEED INDICATOR in the model 108-2 is marked with a white arc from 57 to 100, a green arc from 67 to 121, a yellow arc from 121 to 164, a red radial line (marked "N") at 153, and a red radial line (marked "U") at 164.

19. THE AIRSPEED INDICATOR in the model 108-3 is marked with a white arc from 61.5 to 88, a green arc from 65 to 126, a yellow arc from 126 to 170, a red radial line (marked "N") at 159, and a red radial line (marked "U") at 170.

CHAPTER X

RADIO SYSTEM

TRANSMITTER-RECEIVER UNIT

1. The model 108 airplanes are equipped with General Electric AS-10 two-way radio sets. Subsequent models are equipped with Hallicrafter CA-2 Skyfone two-way radio sets. The transmitter-receiver units of these installations is mounted in the left hand side of the instrument panel. Refer to figures 64 through 67. The loud speaker is installed in the cabin ceiling.

POWER UNIT

2. The General Electric radio has a separate power unit mounted beneath the right front seat. The power unit for the Hallicrafter radio is contained within the receiver-transmitter unit.

ANTENNAE

3. The airplane is equipped with two antennae, an external antenna and a fixed loop antenna. The external antenna on the models 108, 108-1, and 108-2 extends from the cabin roof to the top of the vertical stabilizer. The model 108-3 external antenna extends from the vertical stabilizer to each wing tip with a lead-in wire running to a mast on top of the cabin.

4. To facilitate storage of the airplane, the model 108-3 external antenna is attached to the wing tips with snap clips which provide a ready means of disconnection. When disconnected, it is recommended that the antenna wires be attached near the doors to make immediately apparent to anyone entering the airplane that the antenna is not properly installed for use.

5. The external antenna is used for transmission. An antenna loading coil is installed as a separate unit in the cabin ceiling with the General Electric radio. The antenna loading coil used with the Hallicrafter radio is incorporated within the antenna mast mounted on top of the cabin roof.

6. The fixed loop antenna is installed inside the fuselage, aft of the cabin. The loop is perpendicular to the longitudinal axis of the airplane so that homing is accomplished by flying the null.

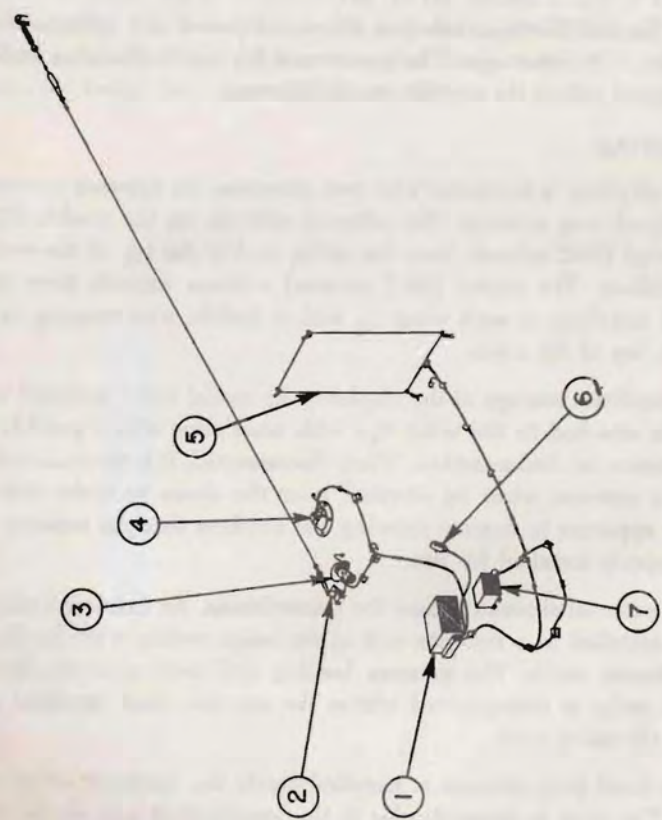

1. Receiver-Transmitter Unit
2. Lead-In Insulator
3. Antenna Loading Coil
4. Loud Speaker
5. Loop Antenna
6. Microphone
7. Power Supply Unit

Figure 64—Radio System (Model 108)

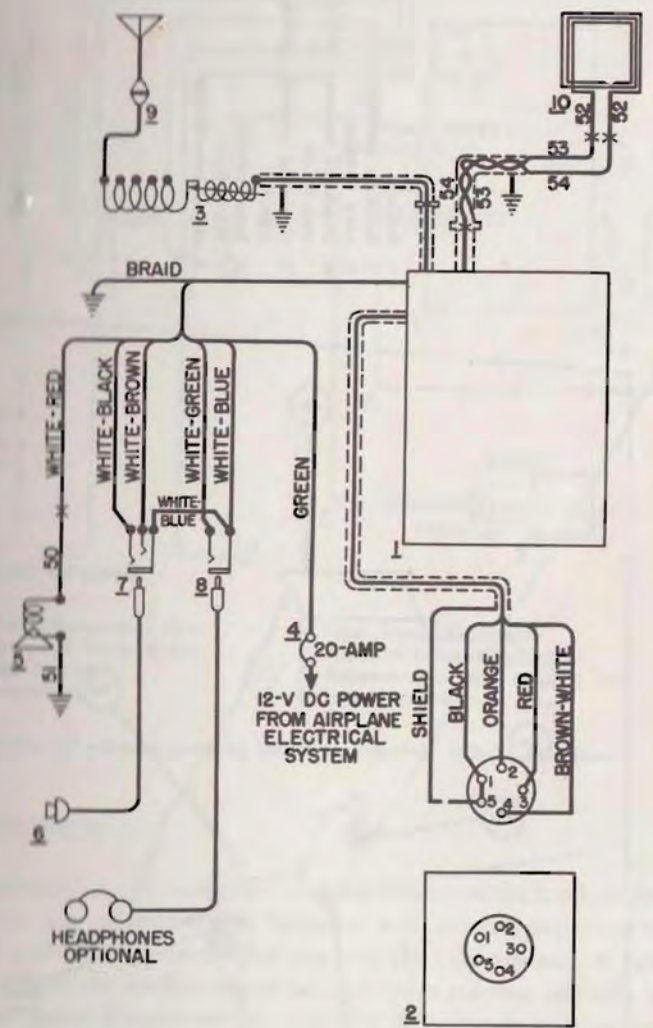
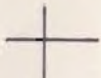

- | | |
|------------------------------|---------------------|
| 1. Receiver-Transmitter Unit | 6. Microphone |
| 2. Power Unit | 7. Microphone Jack |
| 3. Antenna Loading Coil | 8. Headphone Jack |
| 4. Circuit Breaker | 9. External Antenna |
| peaker | 10. Loop Antenna |

65—Radio Cording Diagram (Model 108)

1. Radio
2. Antenna Loading Coil
3. Loud Speaker
4. Overhead Antenna (Model 108-1, -2)
5. Overhead Antenna (Model 108-3)
6. Loop Antenna
7. Microphone
8. Headphone Socket

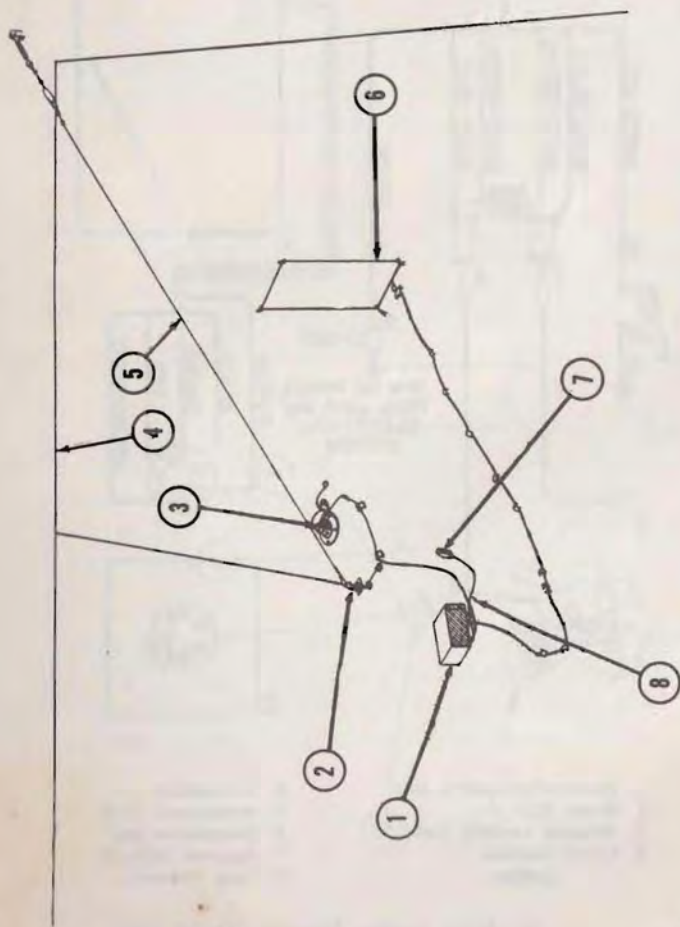
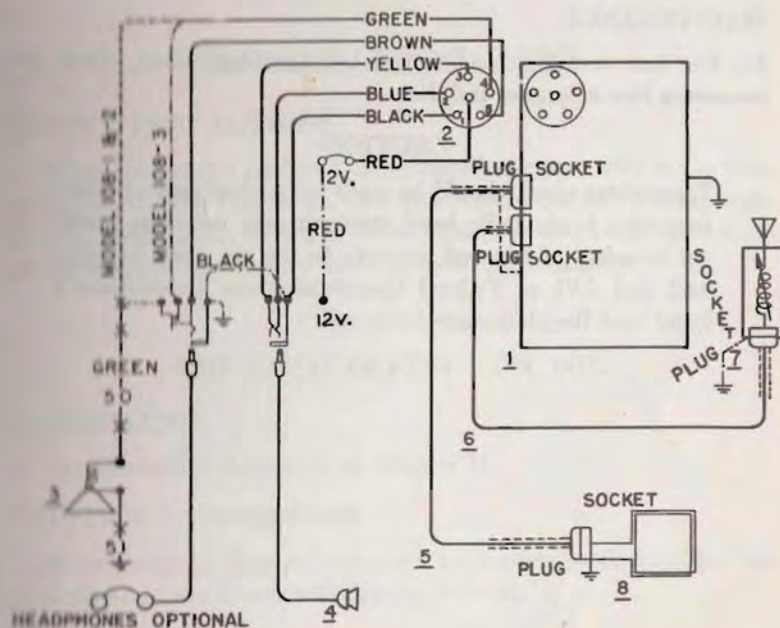

Figure 66—Radio System (Models 108-1, -2, -3)



- | | |
|------------------------------|----------------------------------|
| 1. Receiver-Transmitter Unit | 5. Loop Transmission Line |
| 2. Audio and Power Cable | 6. Antenna Transmission Line |
| 3. Radio Speaker | 7. Antenna Mast and Loading Coil |
| 4. Microphone | 8. Loop Antenna |

Figure 67—Radio Cording Diagram (Models 108-1, -2, -3)

HEADPHONES

7. Headphones are not normally required because of the loudspeaker installation. Use of headphones, however, will increase the range of the radio and is recommended for use with the loop antenna. A jack for plugging in the headphones is located under extreme left side of the control panel. Headphones should be of 600 ohm impedance. On the model 108-3 airplanes, plugging in the headphones will automatically cut out the loud speaker circuit. Refer to figure 67.

OPERATION

B. For operation of the radio refer to the Owner's Operating Manual.

MAINTENANCE

10. For best reception and range, keep antenna masts, wires and insulators free of grease and dirt.

CAUTION

Transmitter check should be made only when control tower frequency is clear. Be brief, transmit only messages essential to safety of life and property in the air. (See Sections 9.62 and 9.91 of Federal Communications Commission's Rules and Regulations.)

CHAPTER XI

SERVICE INSPECTION

SAFETY PRECAUTIONS

1. When installing a new part, or reinstalling a part after it has been serviced, use new Tinnerman nuts and nuts of the self locking type, gaskets, hoses, safety wires, or cotter pins. Use new bolts and nuts in all cases when there is any doubt of their dependability.

Remember

THE PILOT DEPENDS ON YOU

LUBRICATION

2. For lubrication data, refer to Chapter II.

PREFLIGHT INSPECTION

3. Before entering the airplane, make a complete preflight inspection as outlined in the Owner's Operating Manual.

DAILY INSPECTION

4. Before the first flight of each day give the airplane as thorough a visual inspection as time permits. Inspect the airplane in accordance with the procedures outlined in the following paragraphs in addition to those inspections outlined in the preflight inspection.

5. Before entering the airplane, check the following items:

(a) *Propeller.* Inspect the screws that attach the propeller spinner to the hub to be sure that they are tight. Look for signs of cracking of the metal around the screws. If any radial cracks appear around the screws, drill at the ends of the cracks with a number 56 drill, or smaller, to stop the cracks from spreading. Inspect the metal blade tip to see that no rivets are working loose. Rap propeller with fist to see that it is tight. If spinner is not installed, check hub bolts.

(b) *Engine and Engine Compartment.* Examine the parts of the engine cowling that are fastened with screws, to ascertain that the screws are all in place and are tight. Inspect the hinged part of the cowling to be sure the trunk-type fasteners are in good condition. Inspect the inside and outside of the engine compartment to be sure

there are no fuel or oil leaks. Be certain that exhaust stacks and heater mufflers are securely fastened. Inspect the ignition cable terminals at both spark plug and magneto ends to ascertain that the cables are fastened properly and are not grounded.

(c) *Landing Gear.* Check the landing gear fairings for security of attachment. Remove grass or mud from the main gear and tail gear parts.

(d) *Top of Wing.* If the fuel tanks have been filled, be certain that the fuel tank caps are replaced and locked with the vent tubes pointing forward. Wipe off any fuel around the filler necks. Be sure that all access covers are fastened securely. Be certain that there are no rips or tears in the wing fabric. Clean the transparent plastic fairing over the landing lights in the left wing panel leading edge. (Refer to Chapter III, paragraph 2, for instructions concerning care of transparent plastic.) Remove ice, snow, or frost from the top of the wing.

(e) *Under Side of Wing.* Be certain that all access covers are in place and are securely fastened. Inspect the wing lift struts to see that there are no bends, dents, or cracks. Be sure that the screws that hold the strut fairings in place are tight.

(f) *Fuselage.* Be certain that there are no rips or tears in the fuselage fabric. Be sure that the metal cover sheet under the cabin floor is fastened securely. Check the cabin doors to ascertain that the doors are not dented or warped, that the doors open and close freely, and that the latches hold. Clean and polish the transparent plastic windows and windshield. (Refer to Chapter III, paragraph 2, for instructions concerning care of transparent plastic panels.)

(g) *Tail Surfaces.* Inspect the access covers under the stabilizer, on both sides of the fuselage, to be sure they are securely attached. Wipe mud or snow off the tail surfaces. Inspect for dents or cracks. Be sure that control surface hinge bolts are properly fastened. Ascertain that pivot bolts in control surface horns are properly fastened.

(h) *Radio Antenna.* Be certain that the radio antenna is securely fastened, and that the insulators are clean and free from cracks. If wires are dirty, wipe clean with a cloth.

WEEKLY, OR 25 FLYING HOURS INSPECTION

6. Once a week, or at the end of 25 flying hours, if that many hours are logged before a week is up, inspect the following items:

(a) *Propeller.* Inspect the propeller for general condition. Wash the blades with soap and water and rub them with a good polishing wax.

(b) *Engine.* Wash the exterior of the engine with kerosene or other grease solvent. Washing may be done by hand, but some type of pressure spray is preferable. Check the magneto points. The gap when opened should be not less than .017 inch. Check all high tension cables and terminals. If either the magneto terminal or the spark plug terminal of the cable is corroded, replace the cable. Be sure the cable insulation is in good condition. Inspect for signs of chafing on cable insulation.

(c) *Landing Gear and Brakes.* Remove the wheel fairings and inspect the wheels and brakes for general condition. Wash accumulated mud out of the inside of the wheel fairing. Check the brake hoses and couplings for signs of leaks.

(d) *Engine Controls in Cabin.* Operate all the engine controls to ascertain that they move freely through their full travel ranges. Check the primer pump and lines for leaks. Check the condition of grommets or seals around control linkages that go through the firewall.

(e) *Electrical System.* Test the battery with a hydrometer. The reading should be above 1.250. The battery should be recharged if the reading is below 1.250. Add distilled water to the battery solution if necessary. Clean and grease the battery terminals. Inspect the positive and ground leads and connections for general condition. Inspect the generator and starter cables and connections. Clean grease and dirt off the generator. Check the condition of the generator and starter mounting bolts, and inspect for oil leaks at the gaskets between the generator and starter flanges and the engine mounting pads.

(f) *Instruments.* Open pitot-static lines at left side of control panel to drain any accumulated water.

ONE-HUNDRED HOUR INSPECTION

7. Civil Air Regulations (Section 01.25) require that the airplane be given an annual inspection by a certified mechanic, or inspected every 100 hours of flight time if airplane is used for commercial flight operation. The registration certificate, the airworthiness certificate and the Airplane Flight Manual (Approved Operating Limitations), must be in the airplane when it is presented for inspection.

8. The following inspections do not include all the items covered in the Periodic Aircraft Inspection Report, Civil Aeronautics Authority

Form ACA 319 (as revised), but are listed here as an owner's guide to units that require particular attention at the 100-hour period:

(a) *Propeller.* Remove the propeller spinner and check the propeller hub bolts for tightness and proper safetying. The correct wrench torque load for the propeller hub bolts is 125 to 175 inch-pounds. Check the propeller track according to the instructions in Chapter VI, paragraph 4.

(b) *Engine.* Check the valve guides for wear. Press a screw driver against the side of each valve spring and watch for side play on the valve stem in the guide. The valves cannot seat properly if there is excessive clearance at the guides. Replace exhaust valve guides that show evidence of exhaust gases escaping around the valve stem. Replace any intake valve guide if the head of the valve shows evidence of not seating evenly. Check the clearance between the valve rocker arm tip and the valve stem end according to instructions in Chapter VI, paragraph 30. Remove the carburetor and clean it thoroughly.

CAUTION

Clean the carburetor jets with compressed air. Do not clean the jets with a wire.

Remove the spark plugs and clean them thoroughly. Check the engine accessory bolts. Check the engine cooling baffle box for cracks at the attachment screw heads. Check the upper cylinder baffles for cracks. Check the engine controls for general condition and proper functioning. Check the engine mount bolts for tightness and proper safetying.

(c) *Fuel System.* Make a thorough inspection of the fuel lines from the tanks to the carburetor. Drain a small amount of fuel from the plug in the bottom of each fuel tank to get rid of water and accumulated sediment. Examine the selector valve carefully for signs of leaks. Turn the selector valve from right to left tank with the strainer drain cock open to check the flow of fuel through the lines and the selector valve. Clean the fuel strainers. There is one screen type strainer at each tank outlet, one filter type strainer on the left side of the firewall, and a tube type screen strainer in the top of the carburetor body casting, where the fuel hose joins the carburetor.

(d) *Oil Cooler.* Check the lines from the oil cooler to the engine for signs of leaks. Blow compressed air through the core to clean obstructions out of the core cells.

(e) *Air Filter.* Remove the air filter from the bottom cowling and clean it according to instructions in Chapter VI, paragraph 40.

(f) *Cabin and Carburetor Air Heat System.* Make a careful inspection of the exhaust pipe and the heater muff on the engine to be sure there are no cracks or leaks that will allow exhaust gases to enter the cabin or the carburetor. See that the hot air valve gate is closed tight when the cabin heat control is in the *off* position. If air intake duct is left off airplane, also take off heater muff.

(g) *Firewall.* Inspect all grommets and seals where wiring and controls pass through the firewall to be certain that there are no places where exhaust gases can leak into the cabin.

(h) *Engine Compartment Final Check.* Make a final thorough inspection of all wires, hoses, and controls. Be certain that there is no possibility of insulated wires, hoses, or other inflammable material coming in contact with hot parts of the engine or the exhaust system. Be sure that there is no binding or chafing of control arms or levers against wires or engine parts or accessories. Be certain that all metal tubing is looped and supported in such a way that vibration stresses will be minimized. Be sure that insulated wires do not rest on metal parts in such a way that vibration can cause the insulation to wear through and cause a short circuit.

(i) *Cabin.* Renew any instrument or control markings that have worn off or become indistinct. Remove the seats and clean all places that are not easy to clean every day or every week. Repeat the 25-hour battery check while the seats are out. See that vents are not stopped up and that the battery compartment is clean. Repair or replace badly scratched or crazed transparent panels. Inspect the seats, safety belts, ventilators, cabin doors, and carburetor and cabin heat controls to be sure they are in good order. Be sure that all records and log books are up to date. While in the cabin, check the parking brake mechanism. Service the brake master cylinders according to instructions in Chapter II, paragraph 13. Remove the shock absorber cover and add fluid to the landing gear shock struts according to instructions in Chapter II, paragraph 19. Check the landing gear strut attaching lugs. Check the shock struts for signs of leaks.

(j) *Radio.* After all engine and cabin interior inspections are completed and necessary work is done, test the radio while the engine is running to ascertain that the transmitter and receiver operate properly.

CAUTION

Transmitter check should be made only when control tower frequency is clear. Be brief, transmit only messages essential to safety of life and property in the air. (See Sections 9.62 and 9.91 of Federal Communications Commission's Rules and Regulations.)

(k) *Landing Gear.* Jack the airplane at the main wheels (refer to Chapter II for jacking instructions). Remove the wheels and inspect the brakes without disassembling the brake unit. Inspect for any corrosion or broken parts. Check the clearance between the brake linings and the rotating disc. Refer to Chapter V for proper method of adjusting the brake clearances. Inspect the brakes for evidence of seal leaks. Use compressed air to blow particles of dirt and brake lining dust from around the brake housing and the disc. Inspect for the condition of nuts, bolts, and safety wire. Remove grease and oil. Pack the wheel bearings in accordance with instructions in Chapter II. Remove the upper landing gear fairings and the access cover sheet from the bottom of the fuselage. Lubricate the landing gear hinges. Refer to the lubrication chart, figure 15, Chapter II. Check the condition of the wheels. If the protective coating is chipped off or worn through at any place, touch up with aluminum lacquer to prevent corrosion. A recommended formula for aluminum lacquer is 12 ounces of aluminum paste to one gallon of clear dope. Remove the tires and reverse them on the rims so that the worn half of the tread is inboard. Inspect the tail wheel spring and steering swivel for general condition. Lubricate as indicated on the Lubrication Chart, figure 17, Chapter II.

(l) *Fuselage.* Clean the under side of the fuselage. Mend any rips or tears in the fabric according to instructions in Chapter III. Look for signs of rust, corrosion, bends, dents, or other damage to the structure. Be certain that protective coating on the structure is not chipped off or worn through at any place.

(m) *Wing.* Inspect for bends or dents in the wing struts. Be certain that the wing attachment fittings are in good condition and that the bolts are properly fastened. Check for loose drag wires. Remove the strut fairings and ascertain that the strut fittings and attaching bolts are in good condition. Inspect the wing fabric and mend any rips or tears. Be sure that position lights and landing lights are

mounted securely and are in good condition. Clean the top of the wing and restore the sheen with polishing wax.

(n) *Ailerons and Flaps.* Inspect hinges and push-pull tubes for bends, cracks, or signs of wear. Inspect the aileron, and flap surfaces to ascertain that there are no wrinkles, bends, dents, or other signs of damage.

(o) *Tail Surfaces.* Inspect hinges and push-pull tubes for bends, cracks or signs of wear. Inspect the fin, rudder, stabilizer, and elevator for bends, dents, or cracks. If any protective coating is chipped or worn off, restore it with colored lacquer to match the rest of the surface. Be certain that the tail light is in good condition. Check stabilizer leading edge attachment fittings for cracks.

(p) *Surface Controls.* Refer to Chapter IV for control cables fitting data. Inspect for frayed cables and signs of chafing against parts of fuselage, wing, or tail structures.

MAJOR OVERHAUL PERIOD

At the time the engine is disassembled for complete overhaul, give the airplane a thorough inspection because the airplane will be out of service long enough to allow time for removal of parts and coverings that are not generally removed during the routine inspection periods. The number of hours of flying time between major overhauls is not prescribed by either the Civil Air Regulations or the engine manufacturer. A top overhaul after 300 to 400 hours flying time may be required depending on the conditions of operation. A major overhaul after completion of 600 to 750 hours flying time will be required.

SPECIAL INSPECTIONS

1. Certain items may require attention at times that may not coincide with routine inspection periods. Among such items are the following:

(a) *Engine Oil.* The frequency with which the engine oil is changed depends upon operating conditions. When operating from dusty fields, it may be necessary to change the engine oil every 25 hours of operation, or oftener. Under more favorable conditions, the engine oil may be used for 100 hours without changing. Refer to Chapter II for information on the proper grade of oil to use under various weather conditions. It is recommended the oil drained out of

the crankcase be strained through a 20-mesh screen or finer before it is discarded, to make certain no metal particles are present. Metal particles are usually present in oil drained from a new engine, but this does not indicate wear of engine parts. If metal particles are found in oil drained from an engine that has been in service for some time, however, wear of parts should be suspected and the engine should be checked to determine the cause.

(b) *Propeller*. Whenever a propeller is installed, the propeller track should be checked, to ascertain that all the hub bolts have been tightened evenly. Instructions for checking the propeller track are given in Chapter VI.

(c) *Brakes*. Disassemble and inspect the brakes every 400 hours. Remove, disassemble, and inspect the master cylinders on the brake pedals. Install new packings and seals.

(d) *Engine Vibration Absorbers*. Renew the engine rubber vibration absorbers whenever it is evident that they are not performing the function of absorbing engine vibration. Life of the vibration absorbers will be prolonged if the engine mounting bolts are not drawn too tight when the engine is installed. The engine bolts should not be drawn so tight that the engine cannot be moved slightly by hand pressure.

(e) *Compass*. Compensate the compass every four months. Instructions for compensating the compass are given in Chapter IX.

(f) *Wing Drag Wires*. If major repair work is done on a wing panel that necessitates removal of a large amount of fabric, inspect the drag wires before replacing the fabric. Check the tensions of the drag wires and be certain that the tensions are as indicated in figure 21.